



Partially Addressed Mail™ Rate card

January 2019

Helping your business thrive and prosper

In a digital world, consumers place a high value on mail. We believe in the power of 1 to 1 communications to build customer relationships. Technology has transformed communications, but the core strengths of mail have endured and in some cases grown even stronger. Mail helps you connect with your customers and attract new customers in a way that few other channels can, especially when combined with digital.

Royal Mail is the UK's designated Universal Postal Service Provider, supporting customers, businesses and communities across the country. We are the only company that has the capability to deliver a 'one-price-goes-anywhere', six-days-a-week service on a range of letters and parcels to more than 29 million addresses across the UK.

Online Price Calculator

Use our online price calculator to find the best options for your mailing. There's also a downloadable excel version.

royalmailtechnical.com

For prices that are changing in 2019 please visit: royalmail.com/prices2019. For all other prices visit royalmail.com/current-postage-prices

Although correct at the time this price guide was produced (November 2018), postal prices, fees and other conditions are subject to revision from time to time and services may need to be added or withdrawn.

Up-to-date information may be obtained by visiting royalmail.com

Contents

Know your formats	4
<hr/>	
Partially Addressed Mail™ Rate Card	
<hr/>	
Low Sort: Full prices and per gram increments	5
Calculating the price of your mailing	7
High Sort: Full prices	8
<hr/>	
Adjustment Charges	12
<hr/>	

Know your formats

Here are the formats we use to work out the postage. Each format has its own size and weight limits. The illustrations below will help you work out which format your item will fall into.

Letter Up to 100g

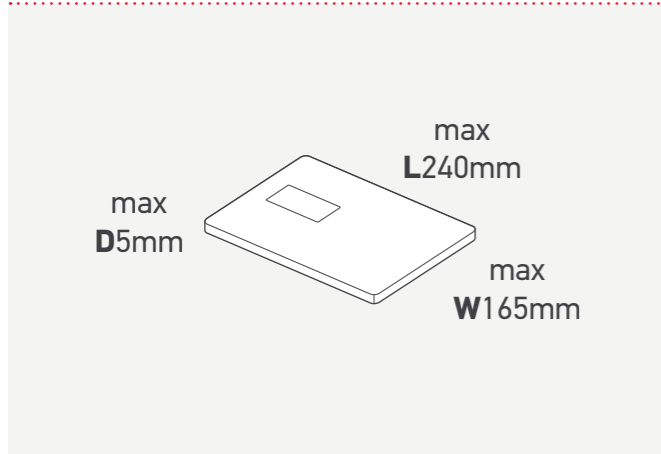

Large Letter - machine readable Up to 750g

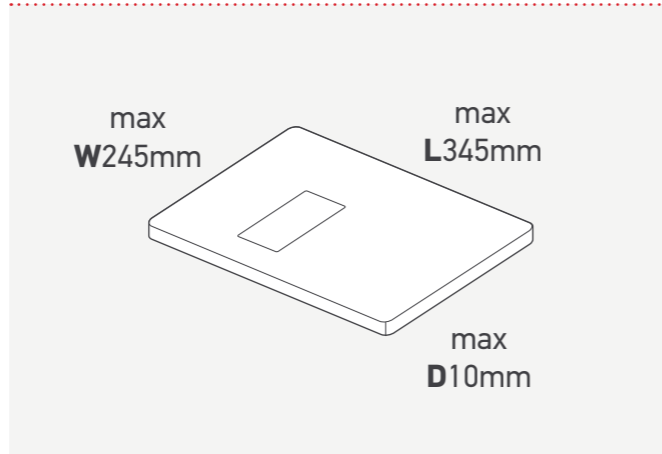

Partially Addressed Mail™

Low Sort Partially Addressed Mail

Table 1 – Full Price & Per Gram Increments

Format	Weight	1st Class		2nd Class		Economy	
		Full Price	Per Gram Increment	Full Price	Per Gram Increment	Full Price	Per Gram Increment
Letter Mailmark	0-100g	53.5p	n/a	24.0p	n/a	21.0p	n/a
Large Letter Mailmark	0-100g	71.8p	n/a	35.9p	n/a	30.8p	n/a
	101-250g	81.3p	n/a	48.8p	n/a	42.3p	n/a
	251-750g	81.4p	0.2239p	49.0p	0.1277p	42.3p	0.1255p

Prices in this table exclude VAT, which is charged at the standard rate.
 Prices in this table exclude the Mailing Standards Levy of 0.2% which is not subject to VAT.
 Further details of the Mailing Standards Levy can be found in the specific terms relating to Partially Addressed Mail.

Low Sort Partially Addressed Mail

Table 2 – Sortation and Machine-Readable Discounts

	Weight	1st Class	2nd Class	Economy
		Direct Items	Direct Items	Direct Items
Letter Mailmark	0-100g	22.83%	22.85%	22.97%
Large Letter Mailmark	0-100g	14.08%	13.82%	14.18%
	101-250g	14.07%	13.84%	14.14%
	251-750g	13.45%	14.01%	14.02%

Partially Addressed Mail™

Low Sort Partially Addressed Mail

Table 3 – Volume Related Discounts*

		1st Class	2nd Class	Economy
Format	Number of Direct Items			
Letter Mailmark	10,000-19,999	0.00%	0.00%	0.00%
	20,000-39,999	1.65%	1.83%	1.88%
	40,000-79,999	3.83%	4.26%	4.37%
	80,000-119,999	4.92%	5.48%	5.62%
	120,000+	5.80%	6.45%	6.62%
Large Letter Mailmark	10,000-19,999	1.50%	1.51%	1.50%
	20,000-39,999	3.56%	3.63%	3.65%
	40,000-59,999	4.59%	4.70%	4.74%
	60,000+	5.41%	5.55%	5.61%

*Volume Related Discounts for Direct items are based on total daily volumes over multiple sales order lines providing all items are posted on the same day; posted from the same posting location (site); posted via the same product and format, and only apply to Direct items (Residue items are not counted towards the calculation).

Please note when you are making a Low Sort posting and have the option on OBA to enter the volume as either Directs or Residues please select the Direct option. While there is only one sorting option available, to ensure that the correct discounts are applied please enter the items as 'directs'.

Mailings of less than 10,000 items may be charged at a higher rate.

Low Sort Partially Addressed Mail

Table 4 – Trayed Mail Discount

	Saving per item
Low Sort Letters	0.30p
Low Sort Large Letters (up to 10mm thick)	0.90p

Discounts apply after all other discounts (VRDs, sortation etc) are applied but before mailing standard levy and VAT.

Partially Addressed Mail™

Calculating the price of your mailing

Step 1: Find the full price for the items you are mailing from Table 1. If the item is Large Letter format and weighs more than 250g, then an incremental price should be added to the full price based on the exact weight of the item. The incremental price is calculated as the incremental weight in grams above 250g multiplied by the gram price increment. The result is rounded to the nearest 1/10th of a penny.

Step 2: Identify the appropriate sortation and machine-readable discount from Table 2.

Step 3: Add to the sortation and machine-readable discount the applicable Volume Related Discount (VRD) from Table 3.

Step 4: Apply the aggregate discount percentage to the full price to calculate the item price.

Step 5: Multiply the item price by the number of items to calculate the total transaction price excluding VAT and Mailing Standards Levy.

Worked example

A Low Sort Economy posting of 102,000 Letters Mailmark weighing 80g each.

Step 1: The full price for a Low Sort Economy option 80g Letter = 21.0p from Table 1.

Step 2: Sortation and machine-readable discount for Low Sort Letter Mailmark = 22.97% from Table 2.

Step 3: VRD from Table 3 = 5.62%, added to the sortation and machine-readable discount of 22.97% gives total aggregate discount of 28.59%.

Step 4: Price per item = $21.0p \times (100\% - 28.59\%) = 14.9961p$.

Step 5: Total price of mailing = $(14.9961p \times 102,000) / 100 = \text{£}15,296.02$ (excluding VAT and Mailing Standards Levy).

Trayed Mail Savings:

Low Sort Letter mailings presented in trays will save 0.3p per item from Table 4 = $(0.3p \times 102,000) / 100 = \text{£}306.0$ (excluding VAT and Mailing Standards Levy).

Total tray price of mailing = $\text{£}14,990.02$ (excluding VAT and Mailing Standards Levy).

Partially Addressed Mail™

High Sort Partially Addressed Mail – Letters only

Table 1 – Direct Full Price

Direct		1st Class	2nd Class	Economy
Format	Weight	Full Price	Full Price	Full Price
Product Code		PAA	PAB	PAC
Letter	0-100g	56.8p	25.1p	20.9p

Prices in this table exclude VAT, which is charged at the standard rate.

Prices in this table exclude the Mailing Standards Levy of 0.2% which is not subject to VAT.

Further details of the Mailing Standards Levy can be found in the specific terms relating to Partially Addressed Mail.

High Sort Partially Addressed Mail – Letters only

Table 2 – Residue Full Price

Residue		1st Class	2nd Class	Economy
Format	Weight	Full Price	Full Price	Full Price
Product Code		PAA	PAB	PAC
Letter	0-100g	61.2p	29.5p	25.3p

Prices in this table exclude VAT, which is charged at the standard rate.

Prices in this table exclude the Mailing Standards Levy of 0.2% which is not subject to VAT.

Further details of the Mailing Standards Levy can be found in the specific terms relating to Partially Addressed Mail.

High Sort Partially Addressed Mail – Letters only

Table 3 – Sortation Discounts

Format	Weight	1st Class		2nd Class		Economy	
		Direct	Residue	Direct	Residue	Direct	Residue
Product Code		PAA		PAB		PAC	
Letter	0-100g	8.51%	6.10%	8.76%	6.35%	8.85%	6.38%

Partially Addressed Mail™

High Sort Partially Addressed Mail – Letters only

Aggregating volumes on Direct selections to achieve and maximise Volume Related Discounts:

In order to reach the VRD threshold on any given posting day, and to maximise the level of VRD obtainable, you can aggregate volumes on Direct selections in 2 ways:

1. You can combine a number of the same product / service level mailings onto one confirmed sales order. You will need to show in the comments field all the job reference numbers or part jobs included on that confirmed sales order. If you do this and then have multiple entries on a single confirmed sales order you must link the individual lines with the appropriate Customer Reference Number (CRN) to maximise your Volume Related Discount.
2. If you are unable to show all mailings for one day on a single confirmed sales order (usually because mailings are at different times) you must put the same Customer Reference Number (CRN) on each confirmed sales order and against each multiple entry. It is not possible to aggregate different sales orders posted on the same day for any unsorted products (Business Mail, Advertising Mail and Business Mail Advance).

Any applicable VRDs are calculated at the time you confirm your sales order and will be reflected on the invoice for that date of posting.

High Sort Partially Addressed Mail

Table 4 – Volume Related Discounts for Direct*

Number of Direct Items	1st Class	2nd Class	Economy
	Direct Items	Direct Items	Direct Items
10,000-19,999	0.00%	0.00%	0.00%
20,000-39,999	1.62%	1.76%	1.72%
40,000-79,999	3.77%	4.11%	4.14%
80,000-119,999	4.84%	5.29%	5.36%
120,000+	5.71%	6.22%	6.32%

High Sort Partially Addressed Mail – Letters only

Table 5 – Volume Related Discounts for Residue*

Format	Number of Direct Items	1st Class	2nd Class	Economy
		Residue Items	Residue Items	Residue Items
Letter	10,000-19,999	0.00%	0.00%	0.00%
	20,000-39,999	1.50%	1.50%	1.00%
	40,000-79,999	2.50%	2.50%	1.50%
	80,000-119,999	2.50%	2.50%	2.00%
	120,000+	3.00%	3.00%	2.00%

*Direct selection volumes or multiple posting volumes against any other sales order lines cannot be counted towards the Volume Related Discount calculation for Residue items.

Partially Addressed Mail™

High Sort Partially Addressed Mail – Letters only

Table 6 – Trayed Mail Savings

	Saving per item
High Sort Letters	0.30p

Discounts apply after all other discounts (VRDs, sortation etc) are applied but before advertising levy and VAT.

Mailings of less than 10,000 Letters may be charged at a higher rate.

Calculating the price of your mailing

Step 1: Find the full price for the items you are mailing from Table 1. If the item weighs more than 250g (above 1000g for Parcels), then an incremental price should be added to the full price based on the exact weight of the item. The incremental price is calculated as the incremental weight in grams above 250g (above 1000g for Parcels) multiplied by the gram price increment. The result is rounded to the nearest 1/10th of a penny.

Step 2: Identify the appropriate sortation discount from Table 2 and Table 3.

Step 3: Add to the sortation discount the applicable Volume Related Discount for Direct (from Table 4) and Residue items (from Table 5).

Step 4: Apply the aggregate discount to the full price to calculate the item price for Direct and Residue items.

Step 5: Multiply the Direct and Residue prices by the number of items in each category.

Step 6: Add the Direct and Residue values together to calculate the total transaction price excluding VAT and Mailing Standards Levy.

Partially Addressed Mail™

Worked example

A High Sort 2nd Class option posting of 102,000 Letters weighing 80g each. 90,000 of these are Directs and 12,000 are Residues.

Step 1: The full price of Directs from Table 1 = 25.1p, The full price of Residues from Table 2 = 29.5p

Step 2: Direct Sortation Discount = 8.76%, Residue Sortation Discount = 6.35% from Table 3.

Step 3: Direct VRD from Table 4 = 5.29%, added to the Direct Sortation Discount of 8.76% gives total discount for Direct items of 14.05%. Residue VRD from Table 5 = 0.0%, added to the Residue Sortation Discount of 6.35% gives a total discount for Residue items of 6.35%.

Step 4: Price of Directs = $25.1p \times (100\% - 14.05\%) = 21.5735p$.
Price of Residues = $29.5p \times (100\% - 6.35\%) = 27.6268p$.

Step 5: Price of Directs in mailing = $(21.5735p \times 90000)/100 = \text{£}19,416.15$.
Price of Residues in mailing = $(27.6268p \times 12,000)/100 = \text{£}3,315.22$.

Step 6: Total for this mailing = $\text{£}19,416.15 + \text{£}3,315.22 = \text{£}22,731.37$
(excluding VAT and Mailing Standards Levy).

Trayed Mail Savings:

High Sort Letter mailings presented in trays will save 0.30p per item from Table 5 = $(0.30p \times 102,000)/100 = \text{£}306.00$ (excluding VAT and Mailing Standards Levy).

Total tray price of mailing = $\text{£}22,731.37 - \text{£}306.00 = \text{£}22,425.37$
(excluding VAT and Mailing Standards Levy).

Adjustment Charges

Mailmark Adjustment Charges

Fault	Applies to	Flat Fee	Per item fee	Notes
Missorts	Mailmark Letters	n/a	13.95p	Adjustment charges only apply when one or a combination of charges result in a charge of £10 or more per eManifest
Missorts	Mailmark Large Letters	n/a	38.75p	
International item as domestic	Mailmark	n/a	£1.56	
Non machine processed	Mailmark Letters	n/a	2.04p	
Non machine processed	Mailmark Large Letters	n/a	3.64p	
Postcode accuracy	Mailmark Letters	n/a	8.05p	
Postcode accuracy	Mailmark Large Letters	n/a	15.78p	
Delivery point suffix accuracy	Mailmark Letters and Large Letters	n/a	0.86p	
Missing or incorrect eManifest ID	Mailmark Letters and Large Letters	£27.23	n/a	
Unmanifested volume and Duplicates	Mailmark Letters and Large Letters	£27.23	0.46p Letters/0.73p Large Letters	
Incorrect SCID	Mailmark Letters and Large Letters	£27.23	n/a	per eManifest
Item ID mismatch	Mailmark Letters and Large Letters	£27.23	n/a	per eManifest

Machine Readable Adjustment Charges

Fault	Applies to	Flat Fee	Per item fee	Note
Low volume faults	Sorted machine-readable	£27.23	n/a	per posting
Medium volume low impact faults	Sorted machine-readable	£27.23	n/a	per posting
Medium volume high impact faults	Sorted machine-readable	£27.23	adjustment	10% of posting adjusted
High volume low impact faults	Sorted and non-sorted machine-readable	£27.23	n/a	per posting
High volume high impact faults	Sorted	£27.23	adjustment	100% of mailing adjusted
Incorrect licence design	BMA on account and Response Services	£27.23	n/a	per month

Prices in this table exclude VAT, which is charged at the standard rate.

*Fee applies to sorted machine-readable mail only.

Full details of the Low/High machine readable faults are available in the Quick Guides at royalmailtechnical.com

Adjustment Charges

Other Adjustment Charges

Fault	Applies to	Flat Fee	Per item fee	Notes
Presentation errors	Sorted	£27.23	n/a	per posting
Incorrect labels/bag ties	Sorted	£27.23	20p	per label or tie
Incorrect cage cards	Sorted	£27.23	25p	per card used
Storage costs	Sorted	£27.23	25p	per cage per day
Overweight bags/bundles/trays	Sorted	£27.23	65p	per bag/bundle/tray generated
Overweight Cages/Yorks	Sorted	£27.23	65p	per Cage/York generated
Minimum average items per selection	Sorted	£27.23	adjustment	100% of mailing
Missing sales order	All products	£27.23	n/a	per posting

Prices in this table exclude VAT, which is charged at the standard rate, except for Bulk surcharges.

*Bulk surcharges are exempt from VAT.

Contact

We hope that this tariff guide has been useful, but should you need any further help or advice, please do contact your Account Manager, or the customer helpline: **08457 950 950***

or through our website:
royalmail.com/contact

Alternative formats

If it would help you to have this booklet in a different format, we can provide it free of charge as:

A large print booklet An audio tape
An audio CD A Braille booklet

Simply call us on **08457 950 950***.

If you are deaf or hearing impaired, we offer a textphone service on **03456 000 606**.



*Calls cost 5p per minute plus your telephone company's network access charge.

Royal Mail, the Cruciform and all marks indicated with ® are registered trade marks of Royal Mail Group Ltd. Partially Addressed Mail Rate Card 2019 © Royal Mail Group 2019. All rights reserved. Royal Mail is a trading name of Royal Mail Group Ltd, registered in England and Wales number 4138203. Registered office 100 Victoria Embankment, LONDON, EC4Y 0HQ.