

Royal Mail

User Guide for

Advanced Letters & Large Letters

2nd April 2024

This is a legally binding document forming part of the Agreement between you and Royal Mail

1



Contents

1. Introduction.....	3
2. Indicia & Licence Plate Requirements	3
2.1 PPI Indicia & Licence Number	3
2.2 Account Barcode Unsorted Indica	7
2.3 Franking machines.....	7
3. Addressing standards	8
3.1 Addressing structure and layout	11
3.2 Required fonts.....	11
3.3 Print Quality	13
3.4 Punctuation.....	14
3.5 Delivery Address Block	15
3.6 Delivery Address Block Clear zone.....	16
3.7 Return Addresses	17
3.8 Clear Zones	18
4. Physical Design – Letters	19
4.1 Other Physical Mailers	25
4.1.1 Perforations.....	25
4.1.2 Pressure Seal' envelope	29
4.1.3 Zip Tie Perforations	30
4.1.4 One Piece & Wrap Mailers	33
5. Physical Design - Large Letters.....	38

1. Introduction

This section of the user guide has the design and technical requirements to enable you to meet the Advanced mail specifications.

This section of the user guide sets out the requirements for the barcode either in licence number indicia, Account Barcode indicia or the Franking Indicia; Delivery Address content, formatting and positioning, Letters and Large Letters physical properties and mail construction and additional requirements for product specific attributes for Advanced mail.

2. Indicia & Licence Plate Requirements

Account Advanced may be presented with the following indicia and Licence options :-

1. PPI Indicia & Licence Number
2. Account Barcode Unsorted Indica
3. Franking Machine

2.1 PPI Indicia & Licence Number

Specific requirements

Account Advanced items require a licence number and, if posting on Account, a Licence barcode to be printed on them. You will receive a discount for each item posted above the minimum volume entry level with a machine-readable address, licence text (three lines of text stating the name of service, class & licence number) and Licence barcode² that can be successfully sorted by us automatically.

You must print the licence text and Licence barcode on the envelope, record your posting details on an Online Business Account (OBA)ⁱⁱ confirmed sales order, and present the items in trays.

The Licence barcode contains encoded information about the service (i.e. BMA), format, speed and licence text. An Artwork Generator to create a graphic that contains the PPI, the licence text and the Licence barcode is available on our [website](#).

- You can use the same Advanced licence number on envelopes, provided the same (and correct) Account number is used for that particular licence number, to post Machine Readable Advanced mail from more than one posting site (for example where you may want to use a single set of printed envelopes). The discount you will receive will be based on the minimum volume threshold (for a discount) being achieved at each posting site, i.e. a lower price than Standard exists for postings of 1 to 249 items and a discount will be available for each posting which reaches at least 250 items per posting site, per day. 1000 items for Advertising mail using Machine Readable Advanced. Item based discounts will not be awarded on Machine Readable Advanced postings which are less than 250 items per posting site, per day.

- Always use envelopes printed with an Advanced licence number supplied by Royal Mail and the related licence barcode (for items posted on account). There will be one licence number for 1st Class and one for 2nd Class for PPI mailings (i.e. posted on Account) we strongly recommend that you use the Machine Readable Advanced Artwork Generator which will produce a graphic of the PPI indicia, the licence plate text (including the licence number) and the related licence barcode.
- Although not recommended, you may create a PPI mail piece using the individual elements by downloading the PPI indicia and using an encoder to create the barcode. The sections below set out the information you will need if you choose to create your mail piece in this way.

Licence plate (made up of licence text and licence barcode) position for PPI mail pieces (i.e. posted on Account):

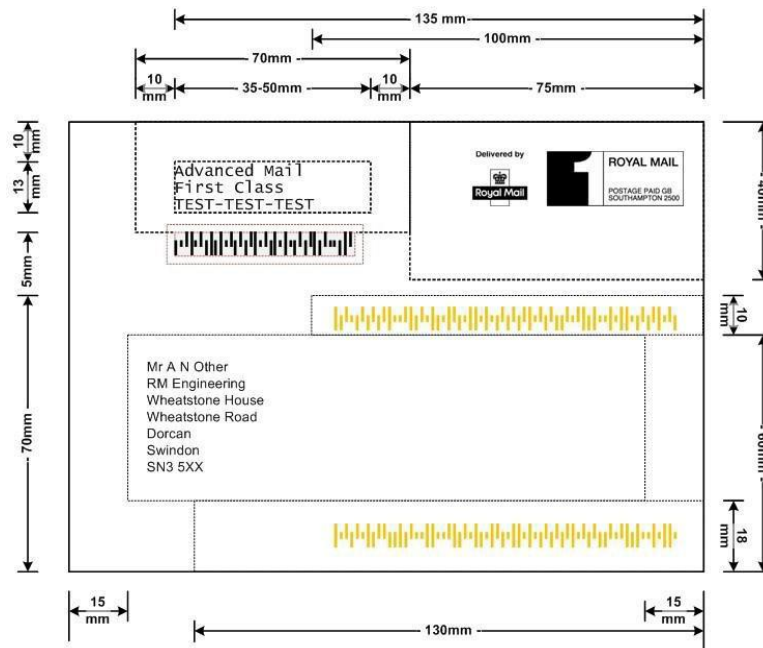

Licence text requirements:

- The licence number is contained within the licence text which will have the following key words and attributes:

For First Class mailings:

Advanced Mail
 First Class
 TEST-TEST-TEST

And for Second Class mailings:

Advanced Mail
 Second Class
 TEST-TEST-TEST

- In the licence number (represented by alpha characters), the 'TEST-TE is the Advanced licence ID and 'ST-TEST' are the related 'Reed- Solomon' error correction characters. There must be no spaces in the licence number (just hyphens).
- The licence text sits within an imaginary box called the licence text box. This licence text box length (from left to right) must be greater or equal to 35mm and less than or equal to 50mm.

Licence plate text specifications:

- licence plate text must be 12pt with normal character spacing
- the fonts for the entire licence plate must be:
 - OCR-B (preferred)
 - Letter Gothic
 - Lucida Console
- text must be left justified
- there must be no font mix within the licence plate
- there must be no use of bold, italic or underlined text
- the first character of each key word must be upper case, all other characters must be lower case
- the licence number characters must be all upper case
- the line spacing must be normal single line spacing
- there must be no outline box
- the licence number and correct characters will be subject to the following character set: ABCEGHJKLRSTUXYZ

Licence text box clear zone

Make sure there is a clear zone around the licence text box (an imaginary box drawn around the licence text) (illustrated in **figure above** by the larger box surrounding the smaller box with the licence text in it). The clear zone around the licence text box has to have these dimensions:

- Left and right (with a return address block or company logo): not less than 10mm
- Left and right (with no return address block or company logo): not less than 5mm
- Top: 10mm exact
- Bottom for PPI mail pieces (i.e. posted on Account): 5mm exact between the bottom of the licence plate text and the top of the licence plate barcode.
- Bottom for franked mail pieces (i.e. posted through a meter): not less than 10mm
- A clear zone of 10mm left, right and above the licence plate text is recommended
- The left side of the licence plate should be between 135mm and 120mm from the right side of the mail piece. 135mm is recommended

Licence barcode clear zone

Make sure there is a clear zone around the licence barcode (illustrated in figure above by the larger box surrounding the licence barcode) of 2mm on all sides. The top side

of this clear zone can overlap with the bottom edge of the clear zone around the licence text.

Licence plate tolerance

For both PPI and franked items, the licence plate and licence barcode has a vertical print tolerance of +/- 2mm and a horizontal tolerance of +/- 2mm. The licence plate must maintain the positional and clear zone constraints.

Printing requirements:

- PPI users should print the licence plate in black ink
- The printing of the licence plate and licence barcode must be no more than $\pm 5^\circ$ to the horizontal plane
- The licence barcode is made up of encoded content which is outputted as a string of text that consists of four characters: D, A, F and T. A special font is then applied which presents each character as a bar. D becomes a 'Descender' bar, A becomes an 'Ascender' bar, F becomes a 'Full' bar, and T becomes a 'Track' bar. An example of minimum and maximum dimensions is shown below:

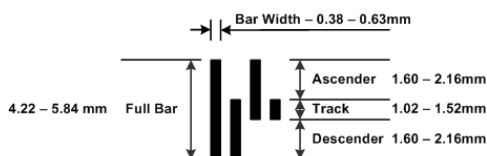

- We advise that licence barcodes are printed using black bars on a white background. Print contrast ratio is a measure of how well the black bars stand out from the background. We require the print contrast ratio to be a minimum of 40%. Please note that 'positive contrast' or 'inverse printing' (e.g. bars lighter than the background) is not permitted
- The print quality must be consistent throughout the licence barcode. The edges of the bars must be sharp and clearly defined. No part of a bar can be less than the minimum thickness or greater than the maximum thickness permitted. We do not recommend printing any licence barcodes using a dot printer but if you choose to there must not be any gaps between the dots within a bar
- There must not be any missing bars or space between characters in a 4-state licence barcode
- The track bars must be symmetrical about the centre line of the code (with a $\pm 10\%$ tolerance of the height of the track bar)

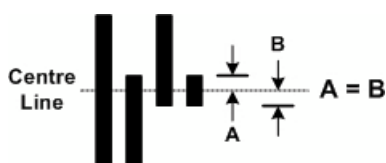

Return address:

With PPI letters, you can print the return address block to the left of the Advanced licence plate, so long as you respect the clear zone. You may limit the line length of the return address block in order to achieve the clear zone tolerance.

2.2 Account Barcode Unsorted Indica

New Advanced customers can use the Account Barcode Indicia supplied by Royal Mail on their Advanced mail items. NB. Each OBA Sales Account either has the Account Barcode products or Advanced products for ordering on OBA Sales Orders (both products cannot exist on the same OBA Sales Account).

The Account Barcode Unsorted Indicia dimensions for the English & Welsh design variants are as follows :-

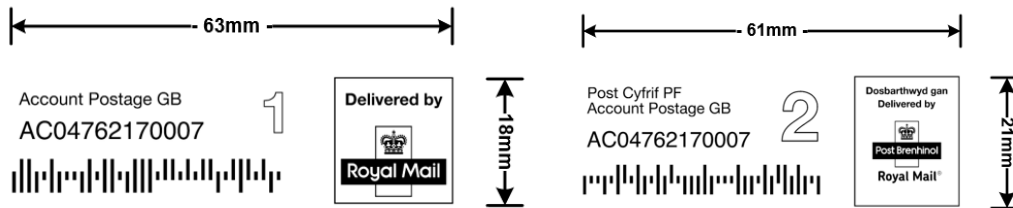

As with other indicia, this must be positioned in the top right corner of the mailpiece in an area that is 75mm long and 40mm high.

2.3 Franking machines

Franking machine prints a 2D Code barcode and your die number and the published price (Standard BMA price including VAT and rounded).

Posters account with their meter supplier is adjusted for the net cost of the BMA postings once a month.

Franking customers using BMA must use white envelopes.

Indicia position for franked mail pieces:

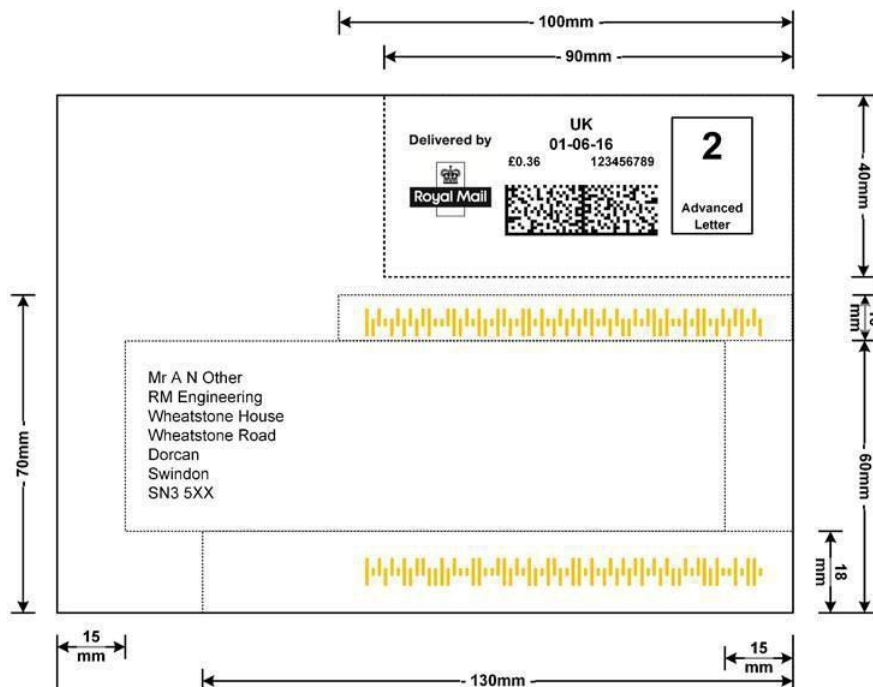

3. Addressing standards

In order for Royal Mail to process and deliver to expected time frames, when addressing inland mail, you must include;

- 1 premise element
- 1 thoroughfare element
- 1 locality element
- the postcode as a minimum

Other elements may be included. If there is no thoroughfare element contained in the Postal address File – (PAF®) this need not be included.

Premise elements	Mailer Defined Information (Optional)	
	Organisation	D Faydherbe Operations Director
	Sub-building	Royal Mail
	Building name	South Wing
	Building number	Bell House
Thoroughfare elements	Dependent thoroughfare	B 25 Bell Complex
	Thoroughfare	The Mews
Locality elements	Double dependent locality	300 Western Road
	Dependent locality	Otterley
	Post Town	Hedge End
postcode	Postcode	OXFORD
		OX4 5ZZ

*see Address structure and layout for details on mailer defined information

Address layout

- Each address element should be on a separate line of the address with the postcode included as the last line of the address. The only exception to this is outlined in section three, Locality elements
- The county, although not required, may be included as the penultimate line of the address
- Country words such as “England”, “Great Britain” or “United Kingdom” should not be used for addresses to and within England, Wales, Scotland, Northern Ireland or the outlying British islands. This information is not included in PAF®
- Each line of the Address Block should be left justified, including the mailer defined information if included

Premise elements

You must include at least one of these 4 elements, so that a single delivery point is defined. You don't have to include all the premise elements, even if they are included in PAF® but building numbers must be applied on the same line as the Dependent thoroughfare or Thoroughfare information.

	D Faydherbe Operations Director
Organisation	Royal Mail
Sub-building	South Wing
Building name	Bell House
Building number	B 25 Bell Complex

Additionally you may place Mailer Defined Information (MDI) on a line above the premise elements of the address and the first character needs to be left justified and aligned to the address block.

Thoroughfare elements

PAF® will give one of 3 possible combinations but please note that:

1. The Dependent Thoroughfare Descriptor (Road, Street, Lane, etc.) must be applied on the same line as the Dependent Thoroughfare information, and
2. The Thoroughfare Descriptor (Road, Street, Lane, etc.) must be applied on same line as the Thoroughfare information:
 - no thoroughfare: no need to include anything in this part of the address
 - a thoroughfare but not a dependent thoroughfare: include the thoroughfare
 - Both a dependent thoroughfare and a thoroughfare: include the former. If space allows you can also include the thoroughfare, though it's not compulsory
3. Building numbers must be applied on the same line as the Dependent Thoroughfare or Thoroughfare information

Dependent thoroughfare	The Mews
Thoroughfare	300 Western Road

Locality elements

You must include at least one locality element. You don't have to include them all, even if they are included in PAF®. The Post Town must have the first character(s) in capitals for example: Coventry, Milton Keynes, Ross On Wye, on a single line.

Where the address complies with the PAF®, and there is no other text/information on the face of the mail item that could be construed as an address, then any of the following exceptions apply:

- The Post Town maybe followed by a county on the penultimate line of the address, provided that the space between Post Town and county is no more than two character spaces and that the postcode is on the last line of the address
- The county and the postcode may be on the same line provided there are one or two character spaces between the two elements

- The Post Town and postcode can be on the same line, provided that the Post Town precedes the postcode and the space between the two elements is one or two character spaces

The requirement for "no other text/information on the face of the mail item that could be construed as an address" includes any areas of an insert which may appear in the window of the mail item arising from insert movement.

The entire Delivery Address should be printed in title case with the exception of:

- The Post Town must be printed in title case or upper case, title case is preferred.
 - e.g. Milton Keynes, ROSS- ON-WYE
- the postcode must always be printed in upper case

Double dependent locality	Otterley
Dependent locality	Hedge End
Post Town	OXFORD

Postcode

- The address must contain the full and accurate postcode. The postcode must be able to generate an address from PAF® which can be matched to the minimum requirements above (at least one premise element, one thoroughfare element and one locality element) the postcode must always appear in capital letters on the last line of the address
- There must be one or two character spaces between the two parts of the postcode. Typically, the first part (i.e. OX4) is the outward code and this identifies a post town or a district within a post town, the second (i.e. 5ZZ) is the inward code which represents the street information

Post Town	OXFORD
postcode	OX4 5ZZ

3.1 Addressing structure and layout

An address may consist of 3 elements, all of which are classed as the Delivery Address Block:

1. Mailer Defined Information (MDI) – reference information printed as part of the Address Block
2. Recipient details
3. Geographical address and postcode



There must only be one Delivery Address Block on the item and it must be on the same side as the payment indicia used.

3.2 Required fonts

There are a variety of fonts you can use, though we recommend you use one from the list below wherever possible. We also recommend you regularly check the quality of your print output for clarity. If you have any doubts on either of these requirements, please contact your account manager.

Please ensure that you do not use any serif, handwritten, *italic* or **bold** fonts and the size of the font should be the same size, or in the case of large letter postings, larger than that used in any Return Address information. Non-proportionally spaced fonts are preferred as is addressing in title case (with the Postcode always in capitals).

Fonts or Typefaces with the following characteristics are suitable:

- **Size** – Height: 2mm min; 7mm max.
Width: 7mm max
- **Dimension** – minimum ratio of lower case height (b) to upper case height (a) of between 2:3 and 3:4. A ratio of width (c) to height (a) of approximately 2:3



- **Consistency** – each line of the address should be in the same typeface and size
- **Quality** – characters should be complete, clear, uniform and of high resolution, with individual stroke thickness of between 8% and 16% of the height of the character
- **Contrast** – there should be a contrast between the characters and the background on which they are printed of at least 50% (55% if it is to be read through a window) positive contrast or inverse printing (address block lighter than the background) is not permitted.
- **Character spacing** – there should be a fixed pitch of between 10 and 12 characters per inch (or between 10 and 12 point size), with clear vertical gaps of at least 0.25mm between the extremities of adjacent characters
- If you are using proportionally spaced text, please ensure you keep spacing of at least +0.75, as this significantly improves the rate at which addresses can be read
- Line spacing – allow uniform spacing between all lines of the address, of at least 1mm - 4mm. There should be no blank lines

Please note:

OCR cannot recognise computer zero (Ø). Script type or italic typefaces also cannot be read.

Preferred Fonts

Non-Proportionally Spaced Preferred Fonts (7) Size 10-12pt	Acceptable Proportionally Spaced Fonts (22) Size 10-12pt	
<i>Courier</i>	Arial	Latha
Courier New	Avant Garde	Lucida Sans
Letter Gothic	Calibri	Mangal
Lucida Console	Estrangelo Edessa	News Gothic MT
<i>Lucida Sans Typewriter</i>	Eurostile	Optima
OCR B	Frankfurt Gothic	Ravi
Word Gothic	Franklin Gothic (Book)	Shruti
	Gautami	Trebuchet MS
	Geneva	Tunga
	Gill Sans	Univers
	Helvetica	Verdana

3.3 Print Quality

The following are typical problems, which can prevent your mail from being processed by an OCR machine:

- **Characters with incorrect proportions**



- **Quality of characters** – which are poorly printed or defined, either because they have been printed by low quality inkjet printers or low resolution dot matrix printers, or because the printer needs maintenance (worn ribbon, low on toner/ink etc.)

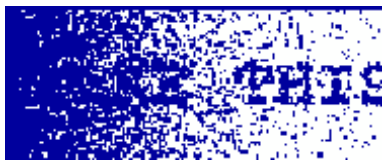

- **Characters with poor outlines** - fuzzy or blurred, or stroke which are incomplete, broken or smeared, for any of the above reasons.
- **Close character spacing** – characters which touch adjacent characters, whether on the same line or those from above or below



- **Proportionally or unevenly spaced text** – characters or words that have too much space between them. The spacing between words should be less than 5mm



- **Typeface styles** – italic, inclined graphic, pseudo-script or handwriting imitations.
- **Typefaces with excessive serifs**, which touch or overlap adjacent characters or serifs, generally, sans-serif fonts are preferable to serif fonts



- **print contrast** – printing white type on a black background or similar, or combinations of colours such as black print on a strong red background

When printing on polymer, the Delivery Address Block should not be distorted or broken text as shown below. The characters should not be blurred, smudged, deformed or incomplete. If using dot matrix printing, particularly on polymer, there should be no gaps between the dots. The print / dot matrix should meet the required contrast ratio

Background Reflectance (BR) and Reflective Difference (RD)

In order to provide sufficient reflectance from the mail piece material that allows sufficient light to be reflected back, a BR value of a minimum of 35% is required. Mail pieces not meeting this requirement will appear as block of dark grey or even black, making it impossible to identify the address on the mail item.

In order to provide sufficient contrast between the mail piece material and the printed address, the RD between the mail piece background and the Printing Reflectance should

e a minimum of 30%. Mail pieces not meeting this requirement will appear as black making it extremely difficult to distinguish the address from the mail piece material

Print Quality for large letter postings;

- The preferred colour is black. If this cannot be achieved then adequate print contrast should be achieved at all times
- It is mandatory for black to be used when printed directly onto the polywrap or polymer envelopes, when the address is printed on an insert in a polywrapped item or when the address is printed on the polywrap outer or label.
- negative contrast is not allowed
- the characters should not be blurred, smudged, deformed or incomplete splashing or ink spatter around characters is allowed

3.4 Punctuation

Punctuation requirements:

- punctuation is permitted for postings which do not receive any other machine- readable discounts
- please do not underline any part of the address or postcode
- in machine-readable letter and large letter postings, punctuation and non-alpha numeric symbols can only be used on the items where it appears in the corresponding PAF® record punctuation can also be used in the recipient's name or in the mailer defined information above the address within the Delivery Address Block. For full details on allowable punctuation within a PAF® record please see PAF® Digest, available from www.royalmail.com, or a member of your account team.
- there should be no punctuation used to separate address elements or components within an address element
- punctuation is permitted within the addressee's name and title / department
- alternatively, you may remove all punctuation from the address, even if it is contained in the corresponding PAF® record

3.5 Delivery Address Block

Delivery Address Block requirements:

- the Delivery Address Block should be left justified and printed in a block of text which includes the recipient's name, geographic address and postcode
- when printing, please ensure that the skew of the Delivery Address Block is less than 5 degrees
- the line spacing of the block of text should be a minimum of 1mm and no more than 4mm
- the spacing of all other words except for the Mailer Defined Information (MDI), when included, within the Delivery Address Block should be within 5mm
- the Delivery Address Block may optionally contain an additional single line of mailer-defined information (for example a reference number or SSC) immediately above the recipient's name on a single line
- you cannot have blank lines within the block and please note that if the line spacing between the mailer defined information and the address block is not the same then the mailer defined information may encroach into the required clear zones
- Where you have chosen to have MDI it has to be in a single line which has no more than 64 characters, be above the address and the first character has to be left justified and aligned to the Delivery Address Block

In addition, while there are no restrictions to the spacing between elements and characters of the MDI the line spacing should be consistent with the Delivery Address. However, you may use a different font and it may be of a different size to the other text of the Delivery Address Block. The MDI should be in typeface and may comprise of letters, numerals, punctuation marks, ideograms and symbols, Barcodes are not acceptable.

The Delivery Address Block is defined by having an imaginary rectangle drawn around the outer extremities of the address including the recipients' name and where included, the mailer defined information.

3.6 Delivery Address Block Clear zone

- No other text/information that could be construed as a Delivery Address may be included on the front of the mail piece. This includes any areas of an insert which may appear in the window of the mail item arising from insert movement
- There is a minimum requirement for a clear area of 5mm or more (see below) to be around the extremities of the full Delivery Address Block. By clear we mean clear of print; patterning, graphics or any text including, when the mail piece is tapped in turn on each of the four sides



- The left, right and bottom edges of the Delivery Address Block should be at least 2mm away from the edge of any label edge provided that there is a total of 5mm clear area between the left, right top and bottom edges of the address block and any print, graphics or patterning on the envelope or any other surrounding material
- Where the Delivery Address Block is on an insert within a window or viewed through polymer, the Delivery Address Block should be fully visible, with the left, right and bottom edges of the Delivery Address Block at least 2 mm away from the window edge, no clear zone is required within the window above the Delivery Address Block, but the Delivery Address Block should always be visible. In total there should be a 5mm clear zone around the top bottom, left and right edges of the Delivery Address Block, which is free from text, graphics or patterning.
- The remaining clear zone requirements are met through the provision of clear zones on the envelope i.e. a minimum of a further clear zone of ≥ 3 mm to the left, right, and bottom of the Delivery Address Block (ensuring that there is 5mm clear in total); and a ≥ 5 mm clear zone on the envelope above the address. (The window edge itself is not considered an infringement of the 5mm clear zone)
- If the MDI is the top line of the Delivery Address Block it may either be totally visible, partially obscured, or totally obscured by the top edge of the window. These requirements apply at all times including after the item is tapped on any or all four edges to induce maximum insert movement. We will accept the addressee details tapping right up to the edge of the window or they can tap out partially to the top and right or completely to the top but recommend they remain fully visible at all times.
- The remainder of the Delivery Address Block must remain visible at all times, and the required clear zones met. These requirements apply at all times, including after the mail item is tapped on any of its four edges to induce maximum insert movement.

For clarification, please see the diagram below showing a Delivery Address Block with the 2mm and 5mm clear zones represented in a window (not to scale): Please note that the following diagrams are not to scale:

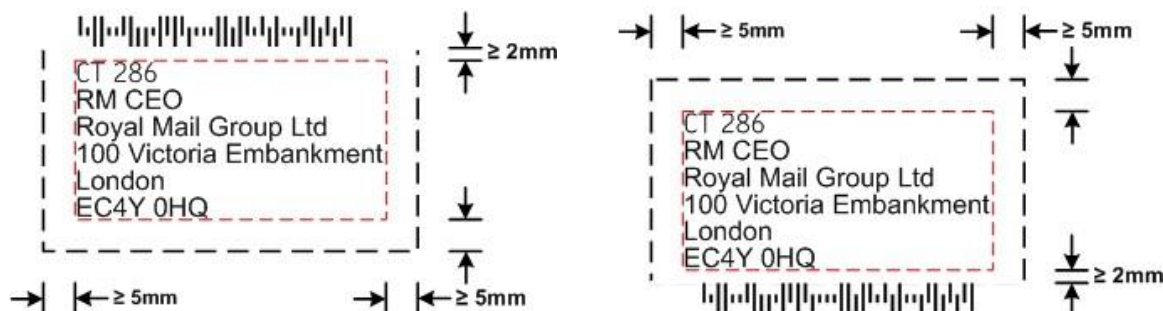

3.7 Return Addresses

We recommend that in each instance you apply a valid UK return address to all your mail as this not only allows us to return items which cannot be delivered but helps you maintain accurate address files.

The following requirements are mandatory for both letter and large letter postings:

- Only one return address must be printed on the envelope
 - Nothing else that looks like a return address must be printed on the envelope
 - The return address may be printed in English or Welsh (where provided in PAF). The inclusion of return addresses printed in both English and Welsh is not permitted.
 - The return address must be prefixed with the words 'Return Address'
- The return address must be a valid PAF address that includes a premise element, thoroughfare element, locality and the postcode.

The addressee information must be included on the second line of the address
Only 'Lucida Gothic' or Letter Gothic' fonts are allowed. Font size must be 10-12pt with normal character spacing and pitch set at 10-12 characters per inch.

No text, patterning or graphics must be printed within the return address

There must be a clear zone of 5mm round the return address

The return address must be printed as a 'block' of left justified text with uniform line spacing (1-4mm) and no blank lines

The return address must always be printed in 'Title Case', with the exception of the Postcode that must always be printed 'UPPER CASE'.

- Each individual element of the address must be on a separate line. Note that the house number and the street must always be printed on the same line
- The Postcode must be printed on the last line of the address or may be printed on the same line as the posttown (with a gap of 1-2 spaces)
- Only punctuation that is included in the PAF address should be included, or alternatively all punctuation can be removed
- The word spacing should be no more than 5mm
- The return address block skew should be no more than plus or minus 5°.

The Return Address on Letter items must be located either;

- On the back of the item and centred within the top 40mm. This is the preferred location as it avoids any confusion with the Delivery Address block.
- On the front of the item in the top left corner (with no element closer than 75mm to the right edge and no closer than 12mm to the Delivery address).

The location requirements of the Return Address for Large Letters are:

- For items up 162mm x 229mm, the Return Address must be located on the back of the Large Letter and centred within the top 40mm.

For items over 162mm x 229mm, the Return Address must be located on the back of the Large Letter and centred within the top 40mm or it may be located on the front of the item in the top left corner (with no element closer than 75mm to the right edge and no closer than 12mm to the Delivery address).

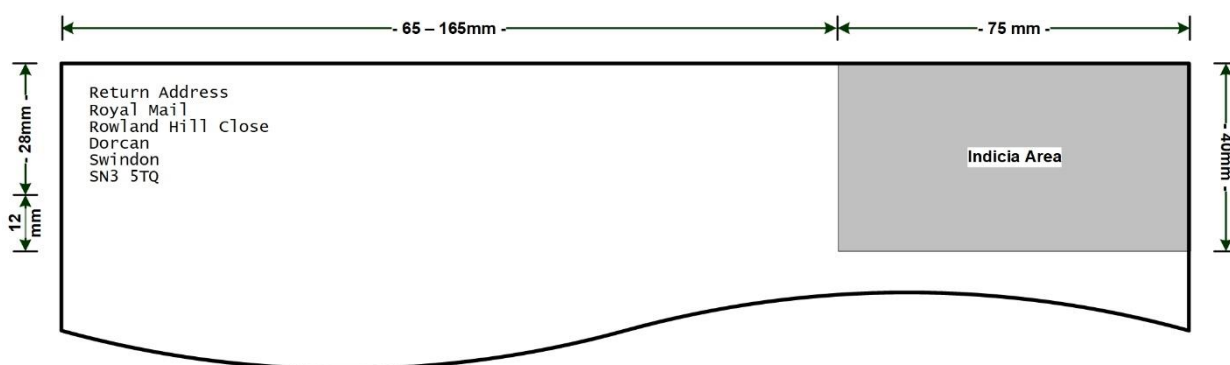

Note: Figure above is not to scale

3.8 Clear Zones

Clear Zones are the areas on your posting you should leave free of any markings. They are used by our machines to print and read code and locate addresses. You should leave Clear Zones in the following areas:

- 5mm around the address (see also above)
- starting from the bottom edge up to 18mm high, stretching to 130mm from the right edge
- starting 60mm from the bottom edge up to 10mm high, stretching 100mm from the right hand edge

In addition, no part of the address should fall within 40mm of the top of the mail piece. However, if you cannot meet this specific requirement, then as long as there is no other print or graphic on the envelope that could be construed as an address, and providing the address conforms to the PAF®, then the address block may encroach into the 40mm clear zone as long as the last line of the address is wholly no nearer than 50mm from the top of the envelope.

4. Physical Design - Letters

Mail pieces must be rectangular (oblong) or square. All four sides must be straight. The intersection of each side should be 90°.

- **Flaps** - opening flaps should be gummed and sealed as far along the edge as possible all remaining edges should be sealed
- **Sealing Tolerances - Trayed Mail**

For DL and C5 Letters with Rectangular or Trapezium shaped opening flaps presented in trays only, there is a maximum tolerance of up to 35mm from the left and right edges and 35mm from the top edge where the flaps do not have to be gummed or sealed.

NB. An envelope manufacturing tolerance of 2mm is permitted i.e. the minimum Letter

Length here is 218mm. See figure 1a and figure 1b.

For Letters that have opening flaps that are less than 218mm long, there is a maximum tolerance of up to 25mm from the right and left edges and 35mm from the top edge where the flaps do not have to be gummed or sealed. See figure 2a and figure 2b

Figure1a - Envelope Flap Sealing – Example 1 (not to Scale):

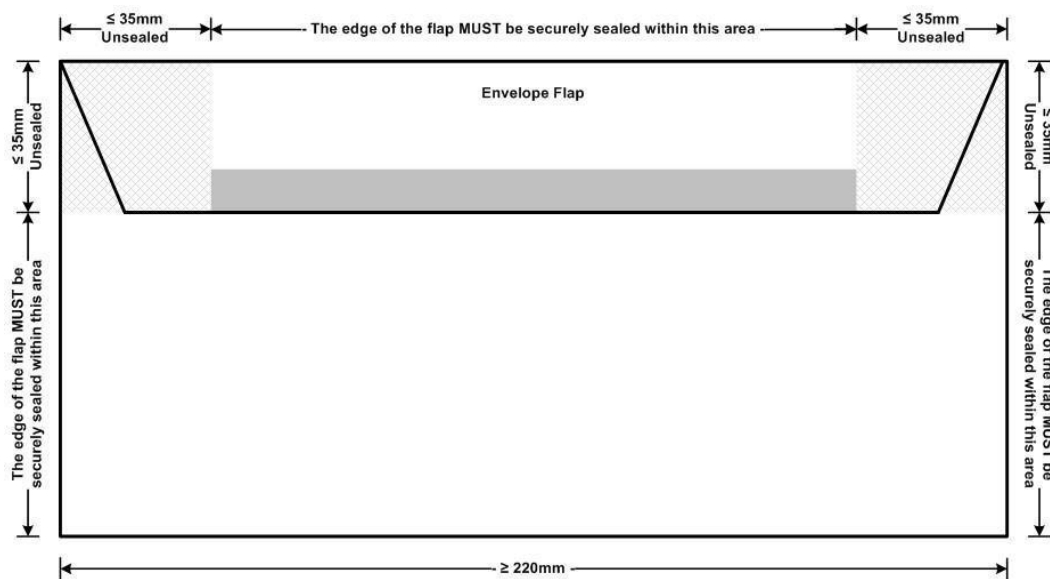
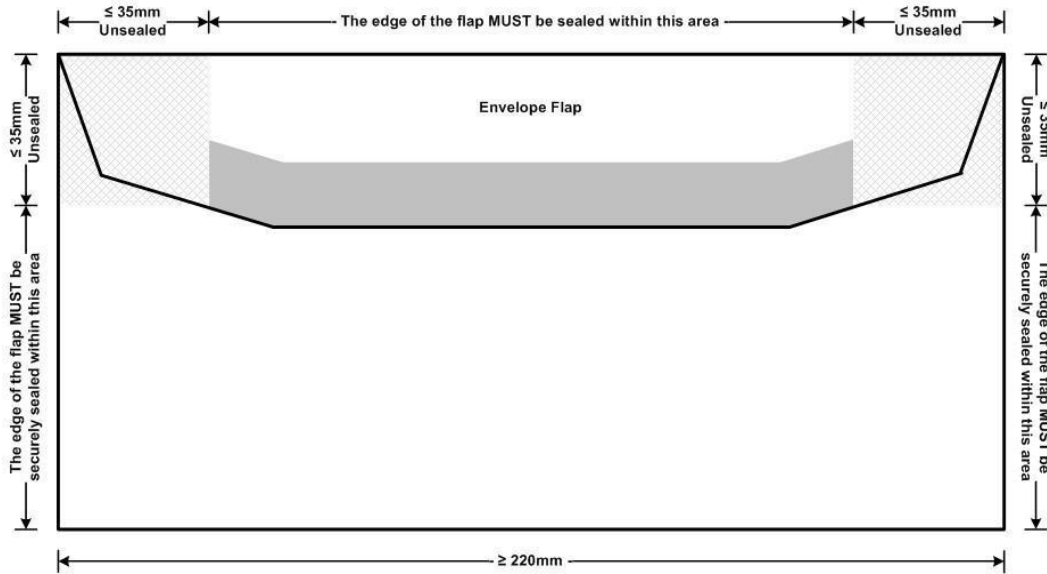

Figure1b - Envelope Flap Sealing – Example 1 (not to Scale):



Sealing Tolerances - Bagged Mail

- There is a maximum tolerance of up to 25mm from the right and left edges and 35mm from the top edge where the flaps do not have to be gummed or sealed. See **figure 2a** and **figure 2b**.

Figure2a - Envelope Flap Sealing – Example 1 (not to Scale):

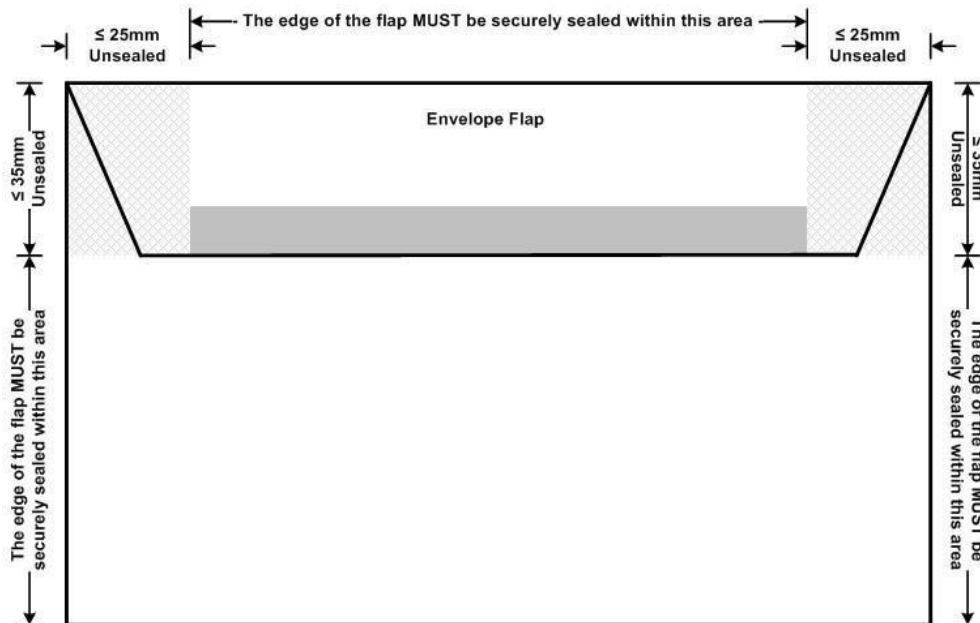
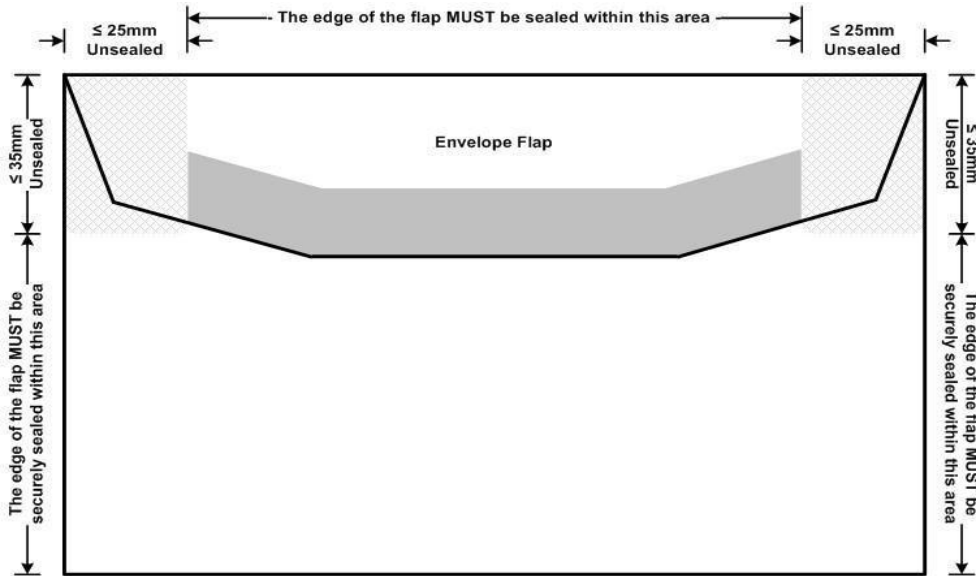

Figure 2b - Envelope Flap Sealing - Example 2 (not to Scale);



Inserts

The maximum amount of lateral movement of an insert within the envelope should not exceed 20mm. alternatively where the overall total mail piece thickness does not exceed

2mm, the maximum allowable insert movement is 30mm. Where envelopes contain more than one insert, the maximum lateral movement applies to the largest insert only, which is not necessarily the insert with the address printed on it. All other inserts within the mail piece may have greater lateral movement. Excessive insert movement within the envelope may cause the envelope to buckle and/or become damaged in our automation equipment.

Metallic items should not be contained within the mail piece with the following exceptions:

- staples maximum size of 24mm by 6mm
- paper clips maximum size of 23mm length

This requirement ensures mail is processed safely without damaging our automation equipment, and thereby safeguarding the mail piece.

Mail piece dimensions

Weight	maximum: 100g
Thickness	minimum: 0.25mm maximum: 5mm
Height*	minimum: 110mm maximum: 165mm
Length*	<ul style="list-style-type: none"> • minimum: 145mm • maximum: 240mm
Square items	minimum 140mm x 140mm maximum 165mm x 165mm

Please note:

- The items should be sealed continuously and securely on all sides
- Rectangular items should have vertical edges which are equal to or shorter than the horizontal edges
- Rectangular items in 'portrait' orientation should be avoided .
These dimensions apply to the finished mail piece

Material

- You cannot use polythene, plastic or transparent items or envelopes with apertures
- To benefit from Sustainable Advertising Mail you will need to adhere to additional requirements – see the product specific Sustainable Advertising Mail User guide
- Opacity - the paper on which the address is printed on should be more than 85% opaque to prevent any character on the back side showing through (BS ISO 2471 paper and board)
- Porosity - < 700 ml/minute
- Absorbency – 15-35g of water in one minute
- Reflection – the background reflectivity of the material on which the address is printed should be at least 35% in the red region (600nm) when measured by a spectral reflectometer
- Envelopes should be made of paper with a density no less than 100g per square metre (gsm). Postcards should be made of paper with a density no less than 200gsm and at least 0.25mm thick.

Flexibility

Items should be flexible enough to be capable of being processed in our sorting machines without damage to the machine, the mail piece, or other mail pieces. Each mail piece should therefore be capable of being transported around a pulley with a radius of 140mm with a maximum force of 26 Newtons.

Figure 13 - Illustration of Flexibility requirement

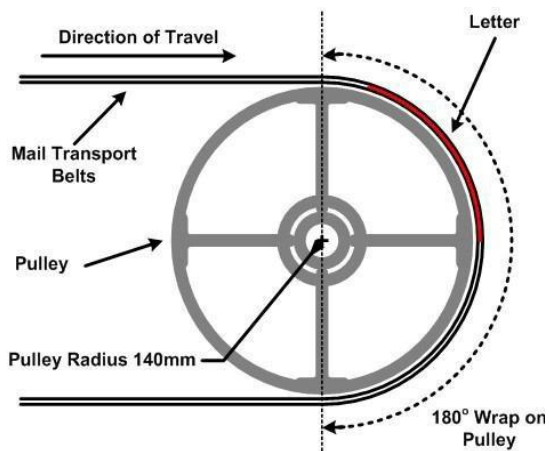

Items that are too stiff will not be able to meet this requirement as shown below.

Figure 14 - Illustration of Failed flexibility

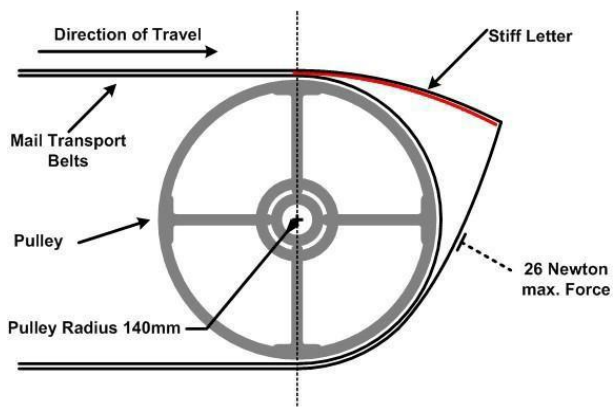

Sealing Advice (for envelope edges, not including the closing flap)

The objective is that the unsealed side seams cannot easily be lifted. This is achieved if the glue is close enough to the edge.

The envelope will have a fold and an opening flap. It should be sealed continuously and securely on the remaining sides which are not the closing flap i.e. the glue used to seal the sides should be in the form of a continuous seal and placed in such a position that the two elements of unglued paper cannot be easily lifted, separated, folded or torn.

Window envelopes - general

- Gloss – the maximum gloss value of the window material is to be 150 when measured at 60° in accordance with ASTM 2457 'Standard Test Method for Specular Gloss of Plastic Films'
- Haze – the window haze should not exceed 75% in accordance with ASTM D1003 'Standard Test Method for Haze of Plastic Films'
- Strength – the window should be robust enough not to become deformed. It should be fixed to the envelope evenly across the surface area it is in contact with
- Windows on mail pieces should normally only appear on the front of the mail piece. However, you have the following options:
 - You may have a maximum of two windows on the front of a mail piece
 - You can have a window on the back of the mail piece providing that the specification as detailed below is met
 - Windows should not take up more than 50% of the surface area of the mail piece

Windows on the front and back of envelopes

Physical properties

- Minimum mail piece length is 212mm (maximum is 240mm)
- Maximum thickness is 1mm
- Paper inserts only
- Maximum weight is 20gsm

Window properties

Standard requirements for machine readable envelopes apply to the front window. The window on the back should be circular with a maximum diameter of 48mm. The perimeter of the window should be 31 +/- 2mm from the bottom of the envelope and centred along the long edge.

4.1 Other Physical Mailers

4.1.1 Perforations

Items with perforations or tear-off strips should meet the specifications detailed below in order to ensure they can be processed efficiently and without any damage being caused. In addition, whilst it is not mandatory, if you wish to post items with either a 'roulette' perforation or a 'zip strip', you have the option of going through part of our QA process as this will enable you to get any new mail piece designs checked prior to posting. Please contact the relevant member of your account team for further advice.

You have the option of using either 'Roulette' or 'Zip Strip' perforations, or designing a 'Pressure Seal' envelope which effectively has double roulette perforations on the back.

Roulette Perforations

- The perforations should be die cut into the items, the cut being the hole, and the bridge being the paper that is left intact and subsequently torn when the mail piece is opened. See **figure 3**.

Figure 3

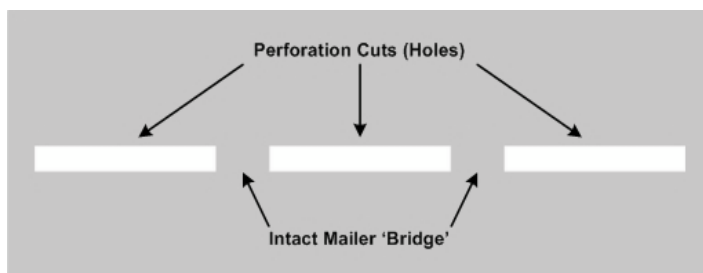

- The paper weight for the items should be $\geq 100\text{gsm}$
- The mail piece should be in either landscape orientation - portrait should be avoided
- The perforations may be located to both 'short' sides of the mail piece, and one of the long sides of the mail piece, i.e. only 3 sides may be perforated as illustrated in **figures 4, 5 and 6**
- The perforations should be inset from the edge of the mail piece by $12 \pm 1\text{mm}$ as illustrated in **figures 4, 5 and 6**
- The cut of the short side perforations should be set at 1.3 – 2mm and with a bridge of 0.8mm as illustrated in **figure 7**. Each cut should be of uniform size and each bridge should be of uniform size
- The cut of the long side perforation should be set at 0.5 – 1.4mm and with a bridge of 0.4mm as illustrated in **figure 7**. Each cut should be of uniform size and each bridge should be of uniform size
- The cuts should be rectangular in shape and have a width of 0.1mm
- The short side perforations should extend from each edge of the envelope as illustrated in **figures 4, 5 and 6**

- The long side perforation should not extend beyond the short side perforations as illustrated in **figures 4, 5 and 6**

The indicia should not be printed over the perforations. Please note that this requirement effectively reduces the area available for your indicia as follows:

1. In landscape orientation where the indicia is adjacent to both 'long' edge and 'short' edge perforations the indicia should be inset and be 12 ± 1 mm on 2 sides (as illustrated in **figure 2**). This limits the area available for your indicia to a maximum of 64mm by 29mm
2. In landscape orientation where the indicia is adjacent to just the 'short' edge perforation the indicia should be inset on 1 side by 12 ± 1 mm (as illustrated in **figure 5**). This limits the area available for your indicia to a maximum of 64mm by 40mm
3. In portrait orientation where the indicia is adjacent to just the 'short' edge perforation the indicia should be inset on 1 side by 12 ± 1 mm (as illustrated in **figure 6a**). This limits the area available for your indicia to a maximum of 75mm by 29mm
4. In portrait orientation where the indicia is adjacent to both 'long' edge and 'short' edge perforations the indicia should be inset and be 12 ± 1 mm on 2 sides (as illustrated in **figure 6b**). This limits the area available for your indicia to a maximum of 64mm by 29mm

- No other colour should be visible through the perforations in the Tag and Route Codemark Clear Zones
- The perforated edges should be securely sealed all round from the perforation to the letter edges
- The glue should not run out onto the outside of the mail item or produce protruding mounds on the mail item
- The glue should be fully cured before you give your mailing to us
- The tensile strength of the glue should be 4.5N and fibre tear should be exhibited on separation

Figure 4- Perforated Mail piece – Top (Not to Scale):

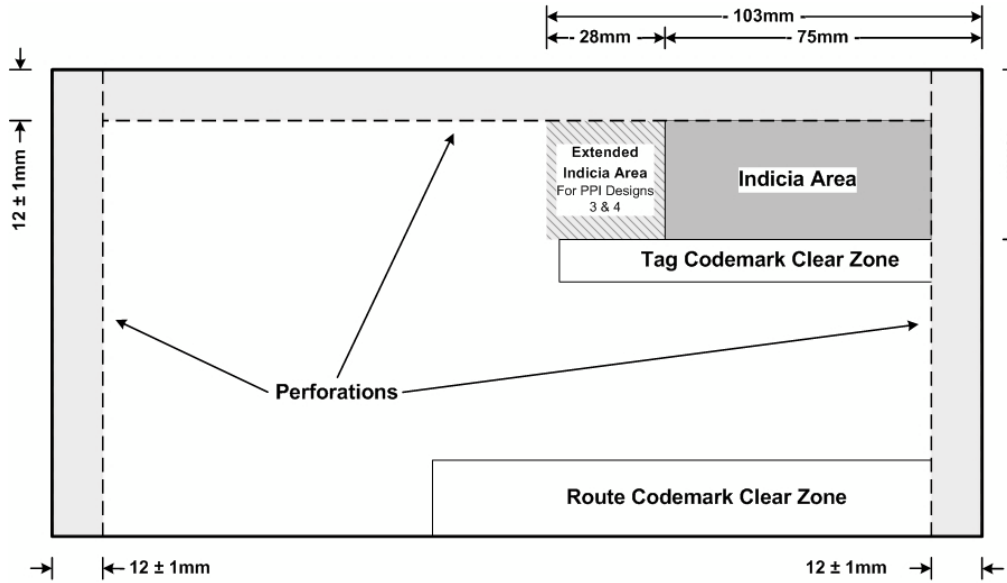

Figure 5 - Perforated Mail piece - Bottom (Not to Scale):

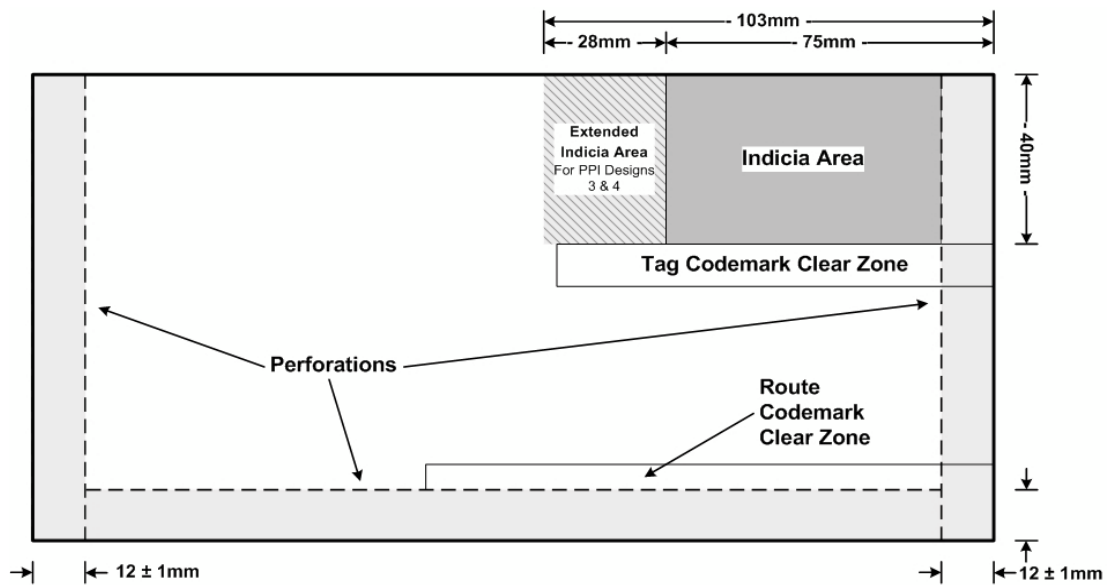

Figure 6- Perforated Mail piece – Portrait (Not to Scale):

6a. Horizontal perforation to the left:

6b. Horizontal perforation to the right:

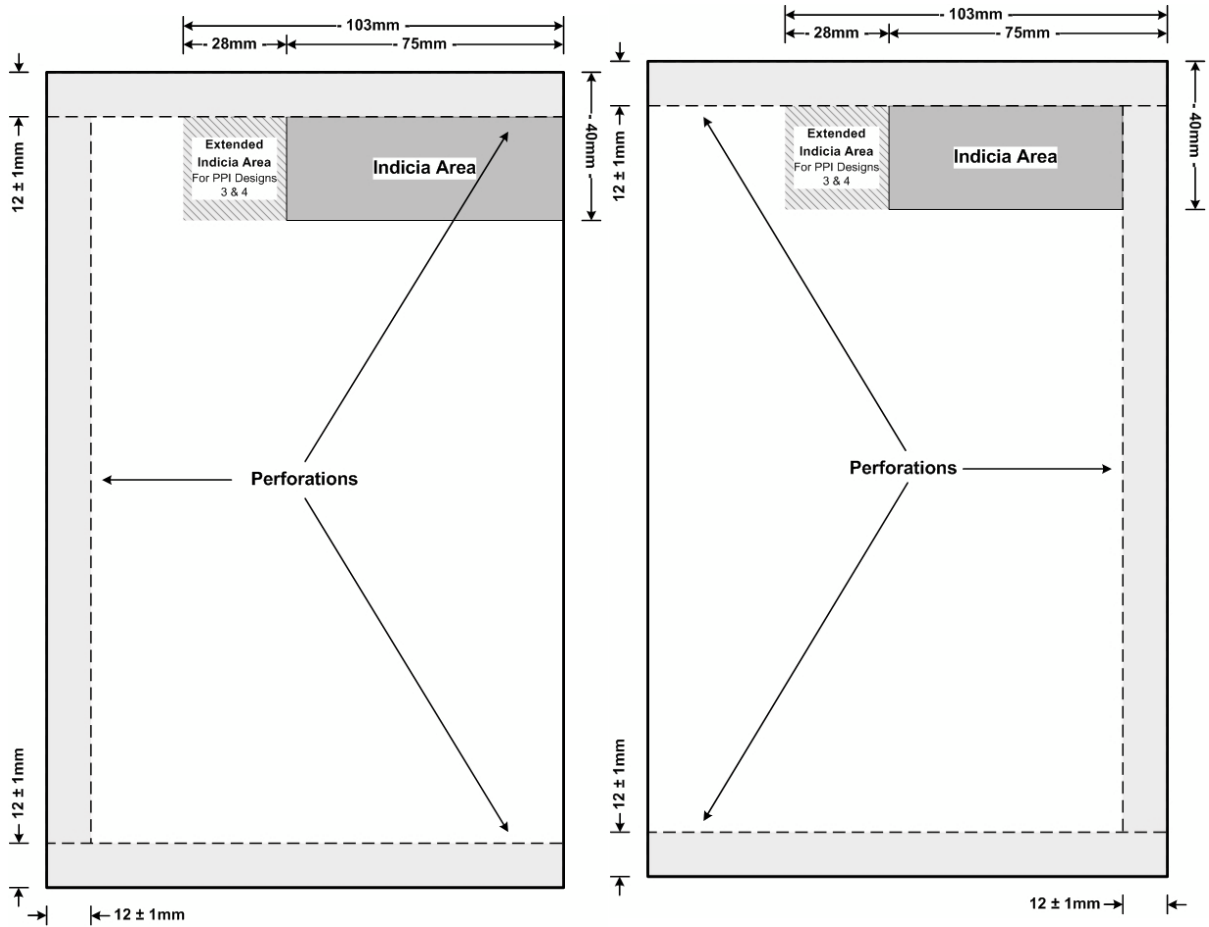
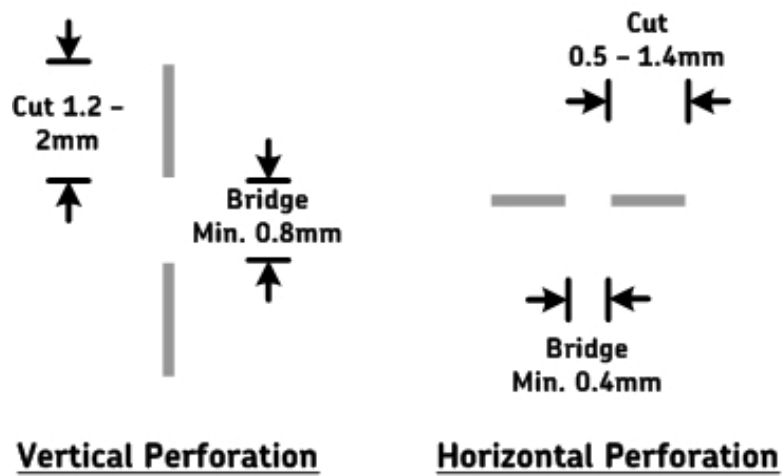

Figure 7 - Perforation Dimensions (Not to Scale):



4.1.2 Pressure Seal' envelope

A Pressure Seal Envelope is a single sheet of paper which has been folded either two or three times to make a DL or C5 size mail piece. The short sides need to be sealed and are opened by means of a standard perforation. One long side has to be a fold, the other will be sealed and have effectively a 'double' perforation to allow the item to be fully opened.

- The short sides have perforations through all layers of the letter (there will be 3 layers of paper for DL or 2 layers of paper for C5 size mail pieces)
- The long side has a Roulette perforation that does not go through to the front of the mail piece. The item is opened by removing the short edge perforated strips first and then tearing back the tear off strip on the back.

Design & general requirements:

- The item is produced from a single sheet of paper
- Inserts are not permitted
- DL design should be $\geq 100\text{gsm}$ (3 ply)
- C5 design should be $\geq 150\text{gsm}$ (2 ply)
- Landscape are permitted (portrait should be avoided)
- Items must not be square
- Perforations to be on both short sides
- The Roulette Tear strip must be on the back of the letter
- The longest edge from the indicia should be a fold (bottom edge for Landscape, left side for portrait)

Perforated strip (short edges):

- As per requirements described under Roulette Perforations the cut of the Perforated Strip perforations should be set at 1.3mm – 2mm and with a bridge of $\geq 0.8\text{mm}$
- The cuts should be rectangular in shape and have a width of $\leq 0.1\text{mm}$

Perforated strip (long edge on back):

- Only one Roulette Tear strip is permitted on each letter it should be die cut into the letter.it should be placed on the back of the letter (i.e. the side which does not have
- The Delivery Address and PPI) and should run parallel to the long edge
- It should be $\geq 10\text{mm}$ from the long edge of the letter & should be $\geq 10\text{mm}$ wide
- The cut should be set at $\leq 3.3\text{mm}$ and with a bridge of $\geq 0.6\text{mm}$ as illustrated in **figure 8** below
- Each cut should be of uniform size
- Each bridge should be of uniform size
- The cuts should be rectangular in shape and have a width of $\leq 0.1\text{mm}$.
- The 'long' perforation may extend into the 'short' side perforations. If this occurs, it should be securely sealed i.e. the strips totally sealed along their length

- The edge between the tear strip and the edge of the letter should be securely sealed along its entire length
- Sealing adhesive should be ≤ 80 microns thick
- The glue should not run outside the mail item or produce protruding mounds
- Glue should be fully cured before the mail is presented to us. The tensile strength of the glue should be $\geq 4.5\text{N}$ and fibre tear should be exhibited upon separation

Figure 8 – ‘Pressure Seal’ envelope perforations & dimensions (not to scale):

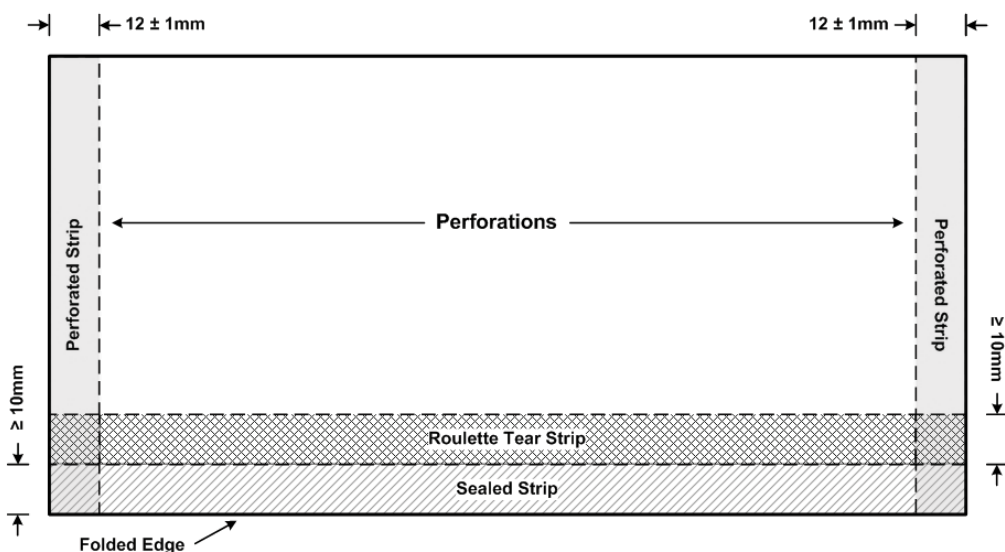

4.1.3 Zip Tie Perforations

- The Zip Tie should be die cut into the item
- The paper weight for the item should be $\geq 150\text{gsm}$
- The items may be presented in Landscape (Portrait orientation should be avoided)
- The Zip Tie should always be placed on the back of the items
- The Zip Tie may be positioned either horizontally or vertically, but the ‘Tear’ direction of the Tie is dependent upon the orientation of the mail piece. **figure 9** and **figure**

10 below illustrate the back of landscape and portrait oriented mail, the orientation, and ‘Tear’ directional requirements (the relative position of the Indicia on the front of the mail piece being illustrated)

Figure 9 - Zip Tie Orientation – Landscape Mail (not to Scale):

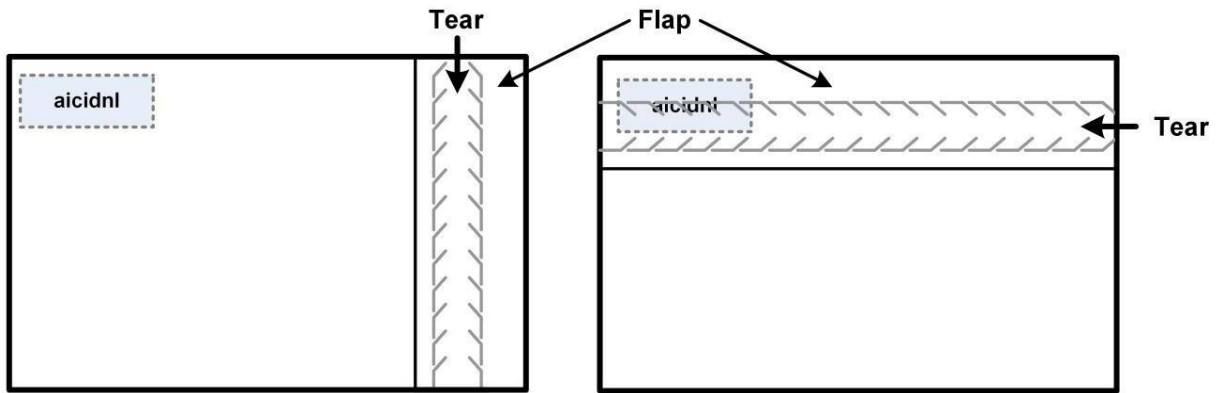
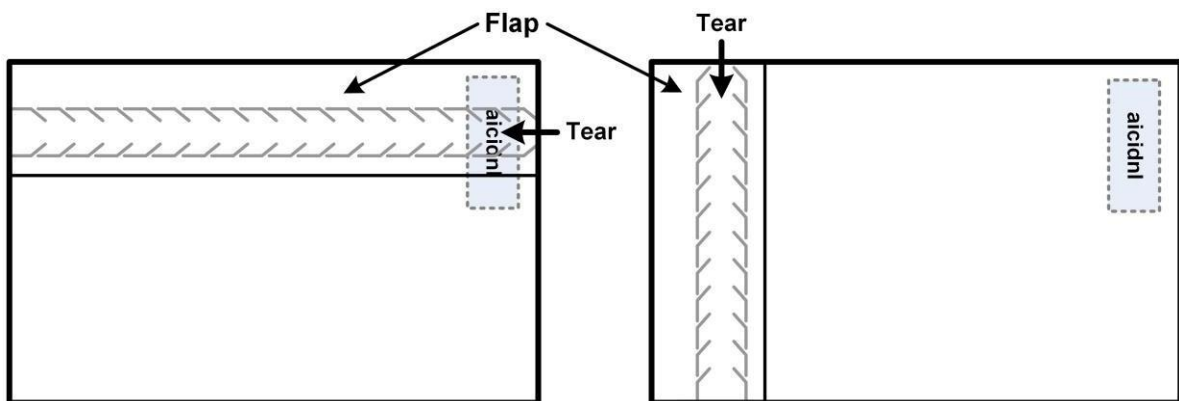
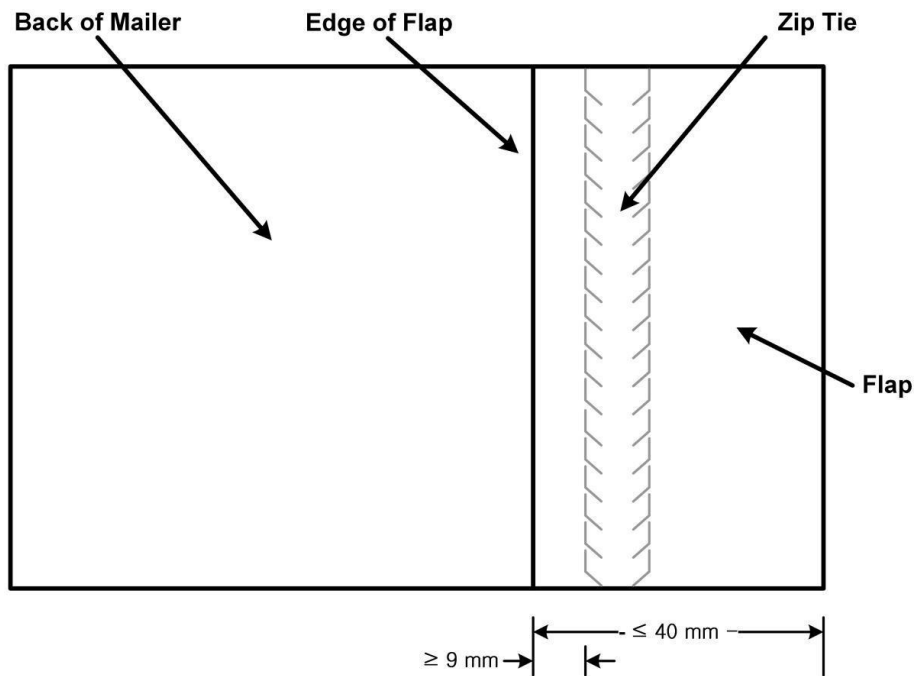

Figure 10 - Zip Tie Orientation – Portrait Mail (not to Scale):



- The Zip Tie should be located on a flap that is $\leq 40\text{mm}$ wide as illustrated in **figure 11**
- The Zip Tie should be positioned $\geq 9\text{mm}$ from the edge of the flap as illustrated in **figure**

Figure 11 - Zip Tie & Envelope Flap (not to Scale):



- The dimensional requirements for the cut of the Zip Tie are provided in **figure 12**

Figure 12- Zip Tie Dimensions (not to Scale):

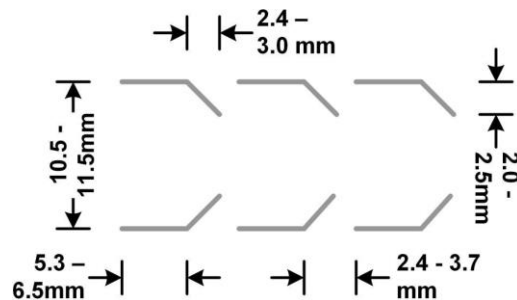

- All cuts and bridges should be of uniform size.
- The cuts should be rectangular in shape and have a width of $\leq 0.1 \text{ mm}$
- The glue used to seal the flap should not run out onto the outside of the mail item or produce protruding mounds on the mail item
- The glue should be fully cured prior to presentation of the mailing to us
- The tensile strength of the glue should be $\geq 4.5 \text{ N}$ and fibre tear should be exhibited on separation

4.1.4 One Piece & Wrap Mailers

Physical design specifications for one-piece mailers;

- A One-Piece / Wrap Letter Mailer is defined as a rectangular or square shaped mailpiece that is made from rectangular or square paper that is folded and sealed. Its unfolded edges being sealed using either glue spots or a continuous glue line.
- An envelope is defined as a rectangular or square shaped mailpiece that is made from polygonal paper which is folded to form a rectangular faced enclosure

Physical Requirements	One-Piece Mailer / Wrap Mailer	Coupon one piece mailer	Feature one piece mailer
Purpose	This option covers the 'Standard' Multi-fold One Piece mailer design, and wrap mailer which provide a one piece alternative to the traditional envelope.	This One-Piece mailer is specifically designed to provide a pocket in which a small booklet can be inserted.	This One-Piece mailer specifically designed to open out easily into a full page feature that is not damaged by fibre tear as a result of gluing.
Inserts	Paper only Permitted	<ul style="list-style-type: none"> • The booklet inserted should be ≤ 85mm x ≤ 130mm in size. • Should be adhered to the mailer to prevent movement of the insert during processing. • Should rest of the reference edge 	Not Permitted
Shape ¹	Rectangular or Square	Rectangular only	Rectangular or Square
Multiple Folds	If Used. All folds tucked internally except flap and all edges sealed	Folded three times to produce a pocket Fold 1 - 70mm from bottom edge. Fold 2 - 215mm from bottom. Fold 3 - 360mm from bottom <i>Figures 17,18</i>	Maximum 2 folds
Reference edge (required to avoid detection as doubles and consequent missorts)	<ul style="list-style-type: none"> • Should be a folded edge. • For Landscape this is the longest edge beneath the address. • portrait items should be avoided this is the longest left edge • For Square Mailers, this may be the edge beneath the address. 	<ul style="list-style-type: none"> • Should be a folded edge. • For Landscape this is the longest edge beneath the address. • portrait items should be avoided this is the longest left edge 	<ul style="list-style-type: none"> • Should be a folded edge. • For this is the longest edge beneath the address. • portrait items should be avoided this is the longest left edge • For Square Mailers, this may be the edge beneath the address.
Mail Piece Dimensions	Minimum and maximum	165mm ± 5mm x 145mm ± 5mm	Minimum and maximum
Thickness	Minimum and maximum	1mm including insert	Minimum and maximum
Max weight	Minimum and maximum	≤ 15g	Minimum and maximum
Paper Weight	≥ 100gsm	≥ 115gsm	150gsm - 190gsm
Paper Thickness	Not applicable	Not applicable	0.13mm - 0.175mm

¹Mailers that are posted into the Collection network should always be rectangular and meet aspect ratio requirements.

Physical Requirements	One-Piece Mailer / Wrap Mailer	Coupon one piece mailer	Feature one piece mailer
Flaps	<ul style="list-style-type: none"> Flap should run parallel to the reference edge and may be on the front or back of the Mailer. The minimum height for a flap is $\geq 25\text{mm}$. The maximum depends on the mail piece size but should be $< 40\text{mm}$ from the bottom of the mail piece. 	Fold 3 forms a sealing flap 35mm deep.	<ul style="list-style-type: none"> Flap should run parallel to the reference edge The minimum height for a flap is $\geq 25\text{mm}$. The maximum depends on the mail piece size but should be $< 40\text{mm}$ from the bottom of the mail piece.
Sealing	<p>With Inserts All unfolded sides should be glued with a continuous seal.</p> <p>No Inserts All unfolded sides should be glued using a spot seal or a continuous seal.</p>	All unfolded sides should be glued with a continuous seal .	All unfolded sides should be glued using a Spot seal
Security	Items securely sealed when presented to Royal Mail	Items securely sealed when presented to Royal Mail	Items securely sealed when presented to Royal Mail
Glue	<ul style="list-style-type: none"> Not Brittle or easily broken The glue should not seep to the outside of the mailpiece The cure time for the glue should be sufficient to ensure that it has fully cured prior to posting 	<ul style="list-style-type: none"> Not Brittle or easily broken The glue should not seep to the outside of the mailpiece The cure time for the glue should be sufficient to ensure that it has full cured prior to posting 	<ul style="list-style-type: none"> Not Brittle or easily broken The glue should not seep to the outside of the mailpiece The cure time for the glue should be sufficient to ensure that it has fully cured prior to posting
Glue viscosity	Should not leak or run onto outside of mail piece nor produce mounds	Should not leak or run onto outside of mail piece nor produce mounds	Should not leak or run onto outside of mail piece nor produce mounds
Peel Adhesion	Peel adhesion strength of glue should be $\geq 0.4\text{N}$ or fibre tear exhibited on separation	<ul style="list-style-type: none"> Peel adhesion strength of glue used for the side seals should be $\geq 0.25\text{N}$ or fibre tear exhibited on separation Peel adhesion strength of the flap should be $\geq 0.2\text{N}$ or exhibit fibre tear when separated 	<ul style="list-style-type: none"> Peel adhesion strength of glue should be $\geq 0.2\text{N}$ on sides Peel adhesion strength of glue should be $\geq 0.25\text{N}$ on the long edge
Glue Weld	≤ 80 microns thick	≤ 80 microns thick	≤ 80 microns thick
Spot Gluing (No Inserts)	<ul style="list-style-type: none"> Distance of two closest edges of glue spots $\leq 10\text{mm}$. Size of spots $\geq 5\text{mm}$. Maximum distance from edge of mail piece $5\text{mm} \pm 2\text{mm}$ <i>Figure 15</i> 	Not applicable	<ul style="list-style-type: none"> Side spots $\geq 11\text{mm}$ in diameter and be $\leq 25\text{mm}$ apart. Long edge spots be $\geq 15\text{mm}$ in diameter and be $\leq 45\text{mm}$ apart. Maximum distance from edge of mail piece $5\text{mm} \pm 2\text{mm}$ <i>Figure 19</i>
Continuous Gluing	$\geq 4\text{mm}$ sealed to within 3mm of the edge	<ul style="list-style-type: none"> Continuous 10mm band of adhesive to the side edges of the mailer. Long edge of flap sealed with 6mm-9mm wide line of adhesive or 2 lines of 2mm-3mm wide adhesive that are 2mm-3mm apart. 	Not applicable
Recommended	10mm clear zone around the perimeter clear of print to ensure adhesive properties of the glue are not impaired <i>Figure 16</i>	10mm clear zone around the perimeter clear of print to ensure adhesive properties of the glue are not impaired	10mm clear zone around the perimeter clear of print to ensure adhesive properties of the glue are not impaired

Spot gluing on standard one piece mailers;

- the distance between the two closest edges of the spots should be $< 10\text{mm}$
- the size of the spot should be $> 5\text{mm}$ in diameter
- the maximum distance from the edge of the mail piece for the glue spots is $5\text{mm} \pm 2\text{mm}$.

Figure 15 – Spot Glue (not to scale)

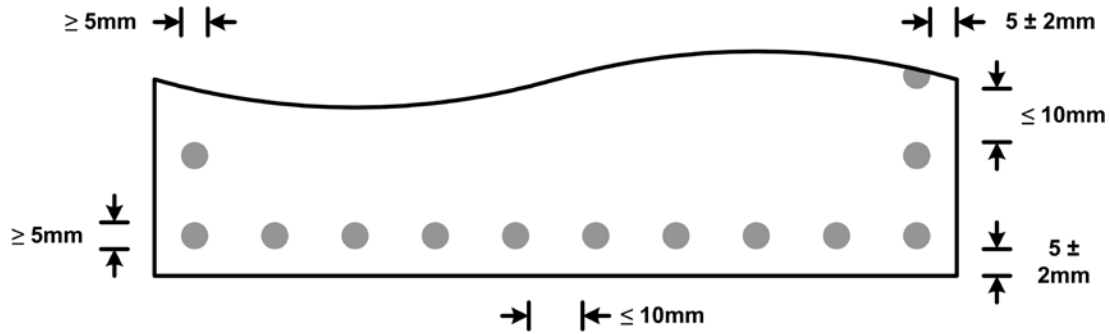

Figure 16 - standard One Piece Mailer



Figure 17 – Finished Coupon Mailer (not to scale)

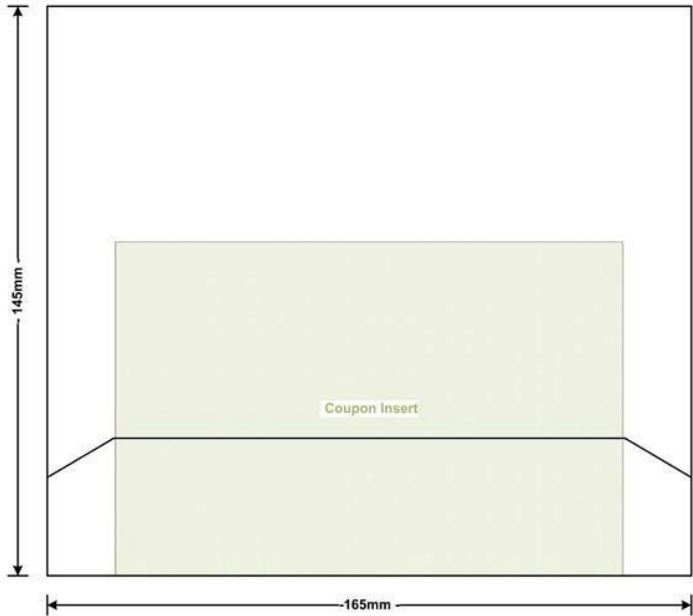
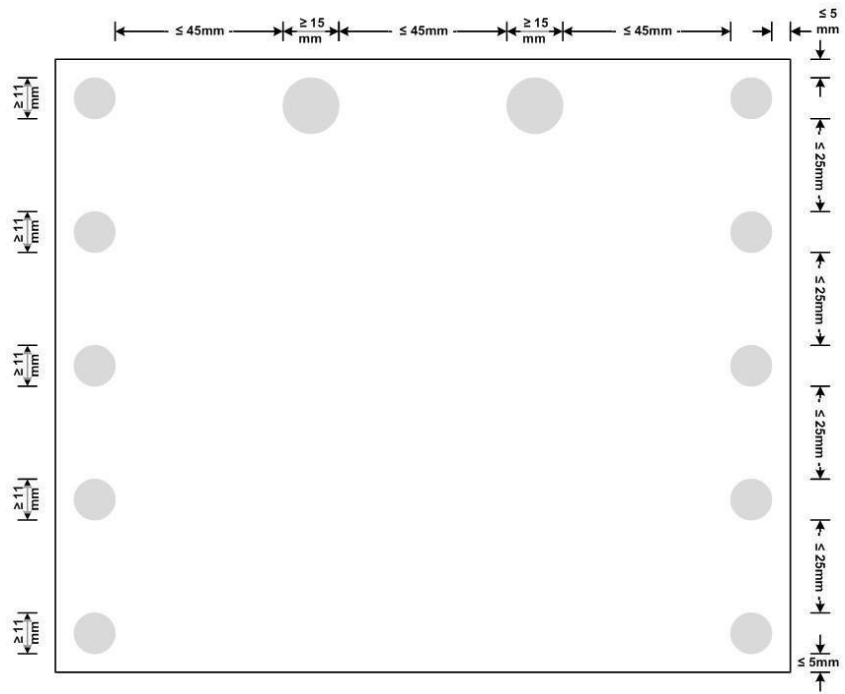

Figure 19 - Feature one piece mailer (not to scale)



5. Physical Design - Large Letters

Getting started

Please can you check the entry requirements i.e. volume, sortation levels and labelling found in the relevant section of this user guide for each product, available on www.royalmailtechnical.com. If you can meet the requirements of the product chosen, you then need to meet the following:

- your items must be within the large letter format but we will permit C5 (162mm x 229) items which are polywrapped (these will be charged at large letter format)

Address standards and printing

You should ensure that you follow the addressing standards and Delivery Address Block requirements as set out in this section of the user guide.

Mail piece dimensions

Weight	<ul style="list-style-type: none">➤ minimum: 10g➤ maximum: 750g
Thickness	<ul style="list-style-type: none">➤ minimum: 1mm➤ maximum: 10mm
Height	<ul style="list-style-type: none">➤ minimum: 95mm➤ maximum: 245mm
Length	<ul style="list-style-type: none">➤ minimum: 145mm➤ maximum: 345mm
Square items	<ul style="list-style-type: none">➤ minimum 229mm x 229mm

Please note:

These dimensions apply to the finished mail piece i.e. the outer covering and including the contents.

Technical requirements

For ease of use, this element of the user guide has been separated into general requirements which cover paper and polymer envelopes and polywrapped mail pieces, then requirements specific to the three outer covering options are listed.

Design of Logos or Advertising

To reduce any potential for Address Interpretation errors, these should not look like an address, geographical location, country or a Royal Mail bag or bundle label and they should not be printed in the Delivery Address Block, the clear zone around it or the Indicia area. Slogans where the company name contains the words 'Return', 'Address' and 'Undelivered' should be avoided.

Please note:

Logos and advertising may go into the general indicia area (40mm x 75mm) area (see **figure 23**) but should not go into the indicia's clear area which varies as follows:

- Response services is variable, please refer to Response Service specification
- PPIs require 2mm clear around the image

Figure 23:

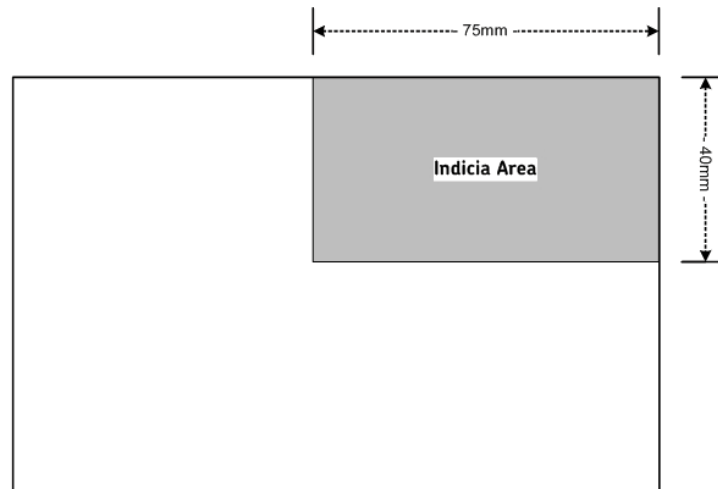

Inserts

For any insert other than the paper contents, you should make sure they are fixed in position so they don't move around during processing. You can use glue or self-adhesive tabs to fix any inserts

- Inserts other than paper that are placed in an envelope should be fixed in position and attached to the insert, such that they cannot move around during the processing of the mail item. The inserts may include small metal objects such as keys, coins, and badges

if you do choose to have any inserts, please be aware that where you have 'step changes' in the thickness of the mail piece, the spatial distortion (see **figure 24**) i.e. variation in the thickness of the contents, cannot be more than 50% of the thickness of the item up to a maximum of 10mm and the address should be on the 'flat side of any item, it cannot be placed on any irregular or convex shaped sides.

Figure 24:

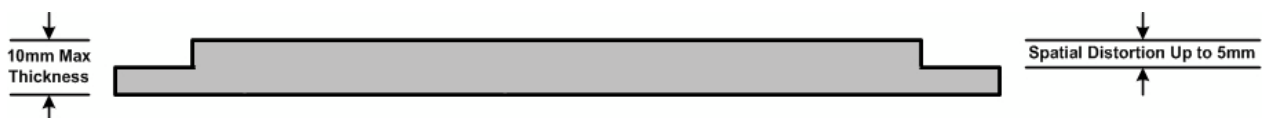

- For paper envelopes - depending on the thickness of your item, to prevent damage to your item and other mail pieces there are limitations on how much 'empty' envelope you can have i.e. the thicker the item, the less 'empty' envelope we would ask you to have (see **figure 25**) . The following applies to the movement of the largest paper insert:
 - if your item is up to 2mm thick then there is no restriction on the lateral movement of the largest paper insert up to the maximum envelope size of 345mm
 - however, for any item which has a thickness of 2mm or more then the lateral movement of the insert within the letter can be 30mm or less

Figure 25:

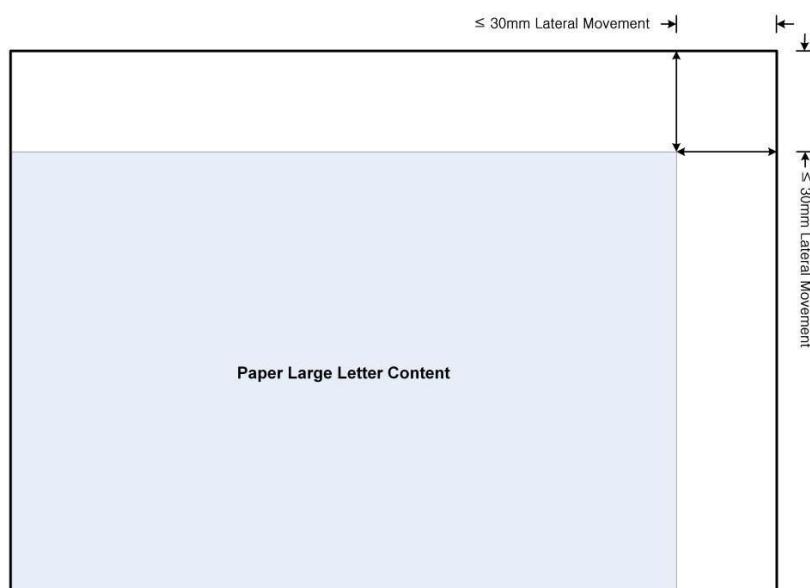

For polymer envelopes or polywrapped items – where the polymer is transparent only the largest insert should be visible to the front of the large letter and the lateral movement is \leq 30mm (see **figure 26**). Please be aware, there is no requirement for the content to be referenced to the bottom left corner, you just need to ensure that there is no more than 30mm along the long edges and no more than 30mm along the short edges

Please note:

For polymer envelopes or polywrapped items you will need to allow for any lateral movement when defining the Address block location. The assumption should be made that the poly may fold during processing and, should this happen we still need a defined clear area from the edge to ensure the Delivery Address Block can be read.

Figure 26:

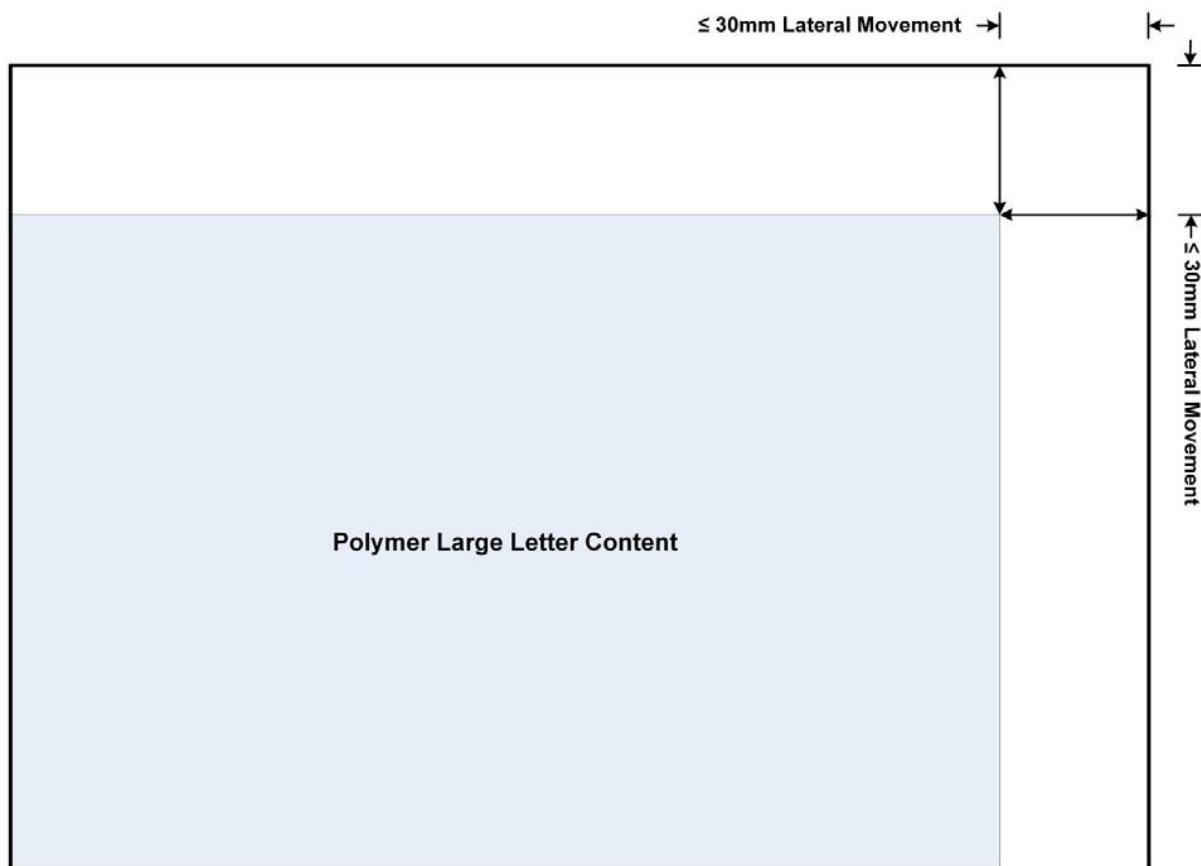

Material - Construction

Paper envelopes

- they should be paper based and no perforations are permitted
- envelope paper weight = 70gsm minimum

Polymer envelopes and polywrap

- it should be made of polymer film e.g. polyethylene
- materials produced from polymer fibres that are randomly distributed and non- directional (laid as a web) and bonded together by heat and pressure are not acceptable e.g. Tyvek

Material - General

- Absorbency (paper based envelopes): 15–35g of water in 1 minute (BS EN 20535 - Paper and board. (Determination of water absorptiveness))
- Glue: Any adhesives used in the production of envelopes should not leak onto the open surface of the envelope and should be dry when the mail is presented to Royal Mail. In no instance should mail pieces be stuck together. When polymer envelopes are used, the glue should be stronger than the polymer and should not produce protruding mounds on the mail item
 - Opacity: $\geq 85\%$ (BS ISO 2471 - Paper and board. Determination of opacity (paper backing))
 - Porosity: < 700 ml/minute (BS 6538-2 - Air permeance of paper and board)
 - Rigidity / Stiffness: The acceptable rigidity / stiffness is ≥ 8 N.mm. There is no upper limit on mail piece stiffness

This can be measured as follows (see **figure 27**):

- A single large letter should be placed on a flat surface with the shortest non spine edge of the large letter overhanging a straight edge of a flat surface by a horizontal distance of 100mm
- The leading edge of the large letter is then released and allowed to bend down under its own weight
- If any part of the leading edge drops to 40mm or more, then the stiffness is less than 8N.mm and the large letter is machine-readable

Figure 27:

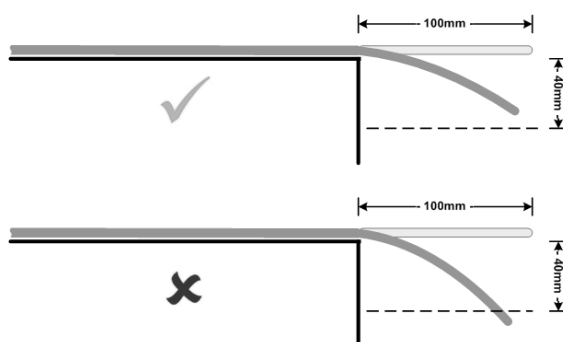

Separation: The items should not be stuck together and should be capable of separating to allow them to be effectively processed. When placed on a slope of 65° to the horizontal, the items should be capable of separating, by sliding one from another, under the force of gravity (see **figure 28**)

Figure 28:

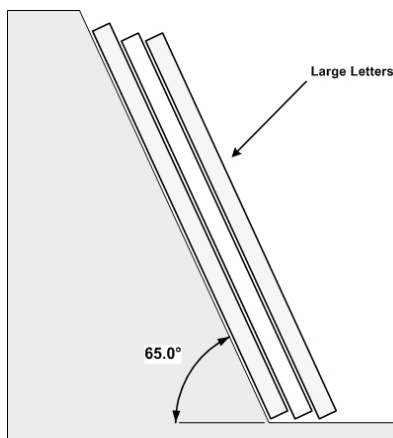

Shape: Items can be rectangular or square within the permitted dimensions and can be laid out (address and payment indicia) in landscape or portrait format. We do require you to ensure that the four sides are all straight lines and intersected by a 90 ° angle.

Polywrap outer

- The film should be intact, undamaged and should not be punctured or torn
- Perforations are not acceptable
- The film should be sufficiently strong enough to tolerate handling without tearing or splitting at the seals
- The film should be > 15 µm (15 microns) thick when measured at any point on the large letter other than the seal
- Any overprinted text should adhere to the film and should not break up or wear during processing
- There should only be a single layer of film covering the Delivery Address Block

Print contrast

- Required Print Contrast Ratio for addresses printed on envelopes ≥ 50 %
- Required Print Contrast Ratio for addresses printed on window inserts ≥ 55 %
- Required Minimum Reflective Difference ≥ 30 %
- Required Minimum Background Reflectance ≥ 35 %
- Inverse printing i.e. negative contrast is not permitted (i.e. address block lighter than background)

Sealing

This section is divided into the paper and polymer / polywrap requirements as they are different.

Paper envelopes should be sealed securely on the back, front and edges. A tolerance of 35mm x 25mm is permitted on the opening flap. Regardless of whether the opening flap is placed on the front or back of the item (the front being where the Delivery Address Block and the payment Indicia are located) it should be sealed to within 35mm from the fold of the envelope and 25mm from the envelope side.

Figure 29:

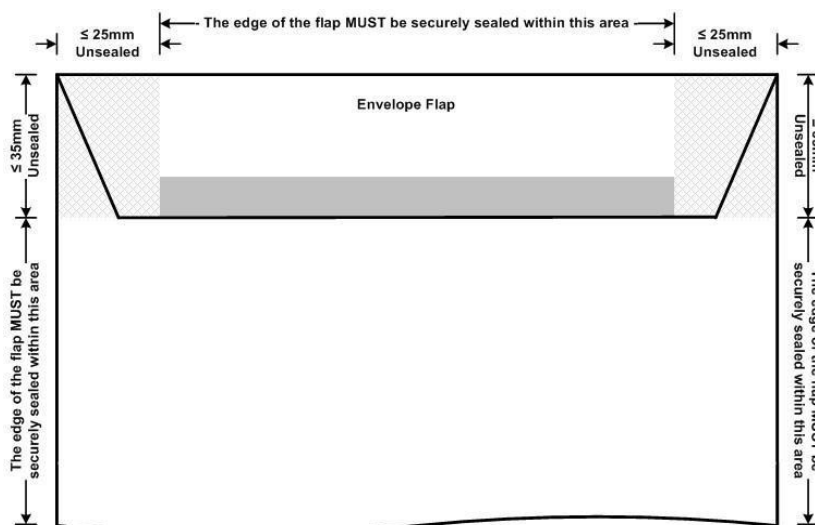
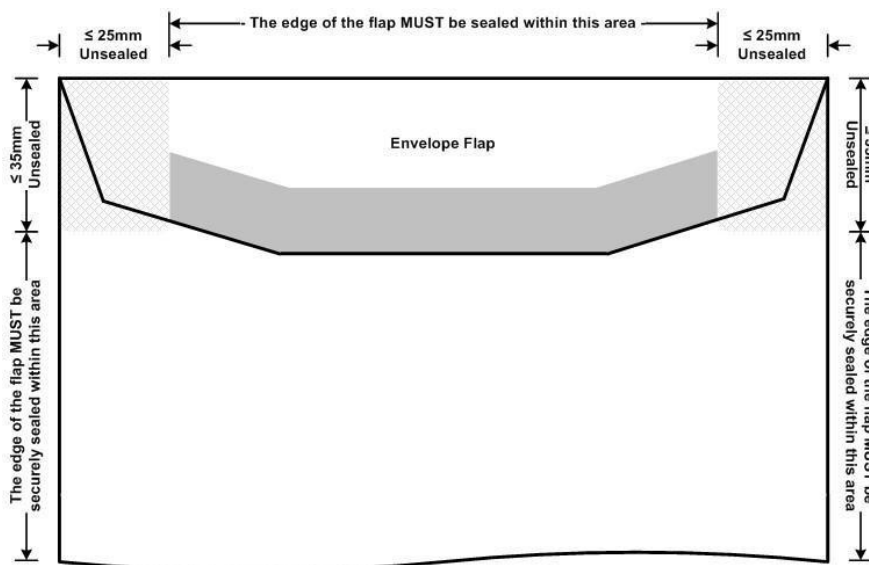
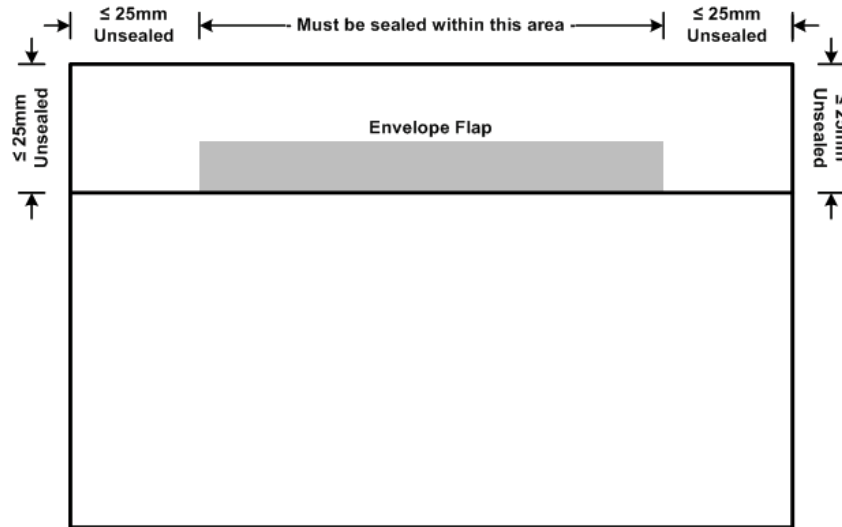

Figure 30:



Polymer envelopes should be sealed along all the edges and have the opening flap on the back (see **figure 29**). The opening flap has to be sealed to within a minimum of 25mm from the fold of the envelope flap and 25mm from the sides of the envelope (see **figure 31**).

Figure 31:



Items which are poly wrapped should be securely sealed on the front, back and side edges. The requirements for any seal which runs along the length, or width, of the item are as follows:

- This seal should be sealed at each end along the full length of the seal
- The free edge of the seal should be less than 30mm deep
- The preferred location for the seal is the back of the large letter
- Due to the requirements for the seal when placed on the front, it cannot be across the width of the mail piece (but if on the back it can)

If you have chosen not to have the seal on the back and have placed it on the front then please ensure you also meet the following requirements:

- the seal should not be over the Delivery Address Block
- the seal should be towards the bottom of the large letter and be no more than 90mm from the bottom edge (see **figure 32**)

Figure 32:

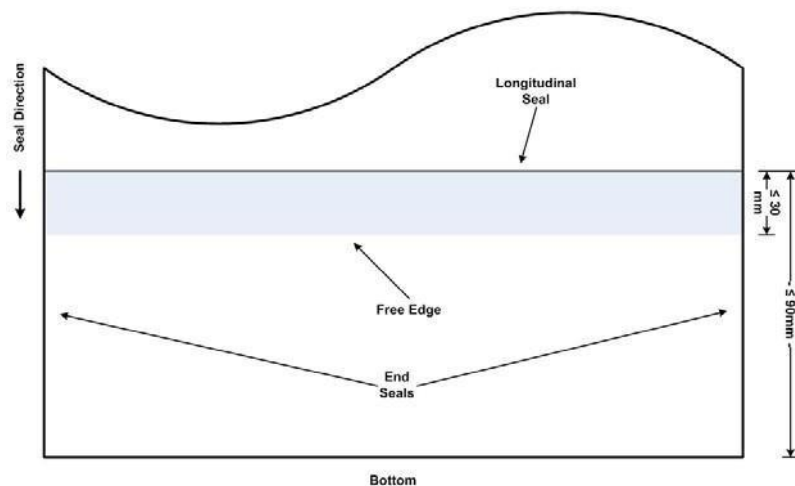

Windows (paper envelopes)

Although you are only permitted one window on your mail piece, you do have the option of using this window for either the Delivery Address Block or for advertising information. You do need to ensure that the window is not an open space i.e. there should be a transparent film covering the aperture and that it is square or rectangular (circular windows are not permitted).

As we don't wish to limit your options when it comes to designing or purchasing window envelopes, we do not have any specific requirements for the strength of the window but you do need to ensure that when we receive the work from you:

- the window film is not flimsy i.e. should be sufficient strength & quality that it is not visibly creased or crumpled
- that it is flat and securely and evenly sealed to the inside of the envelope, this includes the requirement that the corners of the aperture are curved rather than straight as this will help prevent damage occurring when the items are going through the final machine sortation stage
- that it does not take up more than 25% of the surface area on the side where it is found
- Gloss (window and poly film): The gloss value should be ≤ 150 (American standards of testing and materials (ASTM) 2457 Measured at 60 degrees) Haze (window and poly film): The haze value should be $\leq 75\%$ (ASTM 1003-00 Procedure A (Hazemeter))

Delivery Address Block

When printing the Delivery Address Block the maximum characters per line of the address block is 64 and please ensure that the content of one address line is not wrapped onto a second line i.e. Team Valley Trading Estate should be printed on the same line and not spread over two. We ask you to use one of the recommended fonts and sizes (detailed earlier in this section of the user guide) and ensure that each line of the address has characters which are the same font and point size and that the spacing between the words is less than 5mm.

The Delivery Address Block cannot be located in the following areas;

Paper envelopes:

- the indicia area (40mm from the top of the envelope x 75mm from the right)
- the return address area (40mm down from the top and no less than 75mm from the right)
- a 'frame' around the item (15mm around the sides i.e. the left and right edges and 18mm from the bottom)
- over the edge of the envelope flap

Polymer envelopes or polywrapped items:

- the indicia area (40mm from the top of the envelope x 75mm from the right)
- the return address area (40mm down from the top and no less than 75mm from the right)

- a 'frame' around the perimeter of the item (up to 45mm i.e. a mandatory 15mm right and left and 18mm bottom, and the remaining clear area is the excess poly of which 30mm is the maximum permitted)

Therefore, if for example, your mail piece only had 10mm excess polywrap then you would be expected to leave 25mm clear at the right and left edge)* over the edge of the envelope flap